



filteredCOFFEE

user manual
user manual

Contents

Specification	3
Circuits	3
Introduction	4
Appllications	4
Safety Instructions	5
Mounting	5
Quick Start Guide	6
Block Diagram	7
Controls In Detail	8
INPUT LEVEL	8
ENVELOPE FOLLOW LEVEL	8
LFO1 SPEED / LFO2 SPEED	8
High Pass Filter	8
RESONANCE	8
CV1 LEVEL	8
CV2 LEVEL	8
CUTOFF	8
Low Pass Filter	8
RESONANCE	8
CV1 LEVEL	9
CV2 LEVEL	9
CUTOFF	9
AUDIO IN LEVEL	9
VCA	9
Bypass Switch	9
CV1/2 LEVEL	9
OUTPUT VOLUME	10
Rear Panel	11
POWER IN	11
SIGNAL IN	11
SIGNAL IN THRU	11
ENVELOPE OUT	11
PEDAL IN	11
PEDAL CV OUT	11
LFO1 OUT	11
LFO2 OUT	11
HPF CV IN	11
HPF SIGNAL OUT	12
LPF SIGNAL IN	12
LPF CV IN	12
VCA SIGNAL IN	12
VCA CV IN	12
SIGNAL OUT	12
Optional CV Pedal	13
Description of sections	14
ENV FOLW (Envelope Follower)	14
LFO	14
VCA	14
HPF	14
LPF	14

Specification

Rotary Controls:

15

Toggle Switches:

7

Push/Pull Switches:

3

LEDs:

3 - red, yellow, green

Jack Sockets (6.35mm)

14

Size:

1U/1HE (44mm). Width (not inc. ears): 435mm. Depth: 100mm

Weight:

1.5Kg

Power

15V AC input, 500mA

Circuits

Envelope Follower

Low Frequency Oscillator x 2

High Pass Filter (12dB/oct)

Low Pass Filter (12dB/oct) - combined with the HPF produces a Band Pass Filter

Voltage Controlled Amplifier

The HPF, LPF, VCA, and Env. Follower are accurate clones of the Korg MS20 synthesiser which has a distinct sound.

Introduction

Congratulations on buying the Phobos Filtered Coffee.

The Filtered Coffee (FC) is part of the Phobos range of music machines, which includes the Black Coffee analogue monosynth and the Oberkorn analogue sequencer.

The FC is a versatile filter effects unit whose filter circuits are based on the legendary Korg MS20 monosynthesiser which has a unique and distinctive sound. Any audio source can be used with the FC.

The FC has been made to provide a high number of flexible modulation routing to allow many filter effects to be created.

The FC can produce anything from subtle filter sweeps right up to howling, screaming distorted doings. It can also take standard acoustic type sounds and make them 'analogue' - e.g. play 'real' drums through it and get analogue percussion out the other side.

Two FCs can easily be combined to produce stereo filter effects and auto-panning between speakers. This is easily achieved by linking the audio source and the LFO signals using the rear jack sockets.

The FC is based on analogue circuitry, it does not rely on processor speed or software updates, so it's value will keep for far longer than its digital counterparts.

Applications

- an extra effects module for modular synthesisers
- versatile analogue studio effects unit
- live use for DJs and bands
- bringing life to dull sounds
- making digital sounds more 'analogue'
- guitar effects unit

many more!

Any audio input can be used - synthesiser, sampler, microphone, guitar, mixer effects send, drum machine, bass guitar, CD player, DJ mixing decks, anything!



Safety Instructions

Please read carefully before using:

- Only use the recommended power adaptor - 15V AC, 500mA
- Never handle the adaptor with wet hands
- Never excessively bend the adaptor cable, or get it trapped or place heavy objects on it. If the adaptor cable becomes damaged, replace the adaptor.
- Ensure the unit is disconnected from the mains before moving or cleaning.
- Always disconnect the unit from the mains if there is lightning in your area.
- Ensure the unit is on a stable surface, and never place heavy objects on top of it.
- Never allow young children to operate the unit or adaptor.
- Do not use excessive force when using the controls or inserting cables to the connectors.
- The Unit should not be operated in the rain or near water and should not be exposed to moisture. If the unit is brought from a cold environment to a warm one, the unit should be left to reach the ambient temperature. This is to allow any possible condensation moisture inside the unit to evaporate. Although any built up moisture will not damage the unit, any shorting may be hazardous.
- Never open the case or attempt to make repairs. Refer any servicing to a qualified service personnel.

Mounting

The FC can be rackmounted in any standard 19" rack case. It requires only 1U, and very little depth. Always use all 4 mounting holes so it is secured in the rack.

Alternatively, just place the unit on a stable surface. Rubber feet can be stuck on the base to stop it sliding about.

Quick Start Guide

This section is intended for those who just want to quickly plug in the unit and get going;

- Ensure the unit is switched off
- Plug your audio input to the rear panel Audio In socket
- Plug the rear panel Audio Out socket to your mixer
- Turn the input level and output volume controls to minimum
- Set up your mixer levels as appropriate
- Power up the unit

- Turn the LPF AUDIO IN LEVEL pot to maximum
- Move IN/BYP switch to IN
- Move the VCA switch 2 to THRU
- Turn the VCA CV1/2 LEVEL control to maximum

- Turn the HPF CUTOFF control to minimum
- Turn the LPF CUTOFF control to maximum

- Set the main output level to around 50%

Now, slowly increase the INPUT LEVEL. A signal should start to be heard. The INPUT LEVEL needs to be adjusted as high as possible without distortion (unless you require distortion as this can be a useful effect). You will need to balance the OUTPUT VOLUME so you do not overload your mixer.

Now you should be up and running with a fairly un-effected signal. Remember, this is an analogue effect based on a very old discrete circuit, so some colouration of even an un-effected sound is possible!

Play around with the other controls for nice filter effects.

With digital effects, there are a wide range of presets. You switch the unit on and will instantly be wooed by the stunning DSP effects.

Analogue effects units do not have presets. Depending where the knobs are set to, you may switch the unit on and get a very dull and uninspiring sound. The FC can produce a wide range of filter effects, most are fantastic, but some you may not like. You will need to play around with it for a while till you learn how to get the best out of it. As you become familiar with the unit you will soon find out the best settings for your tastes.

Block Diagram

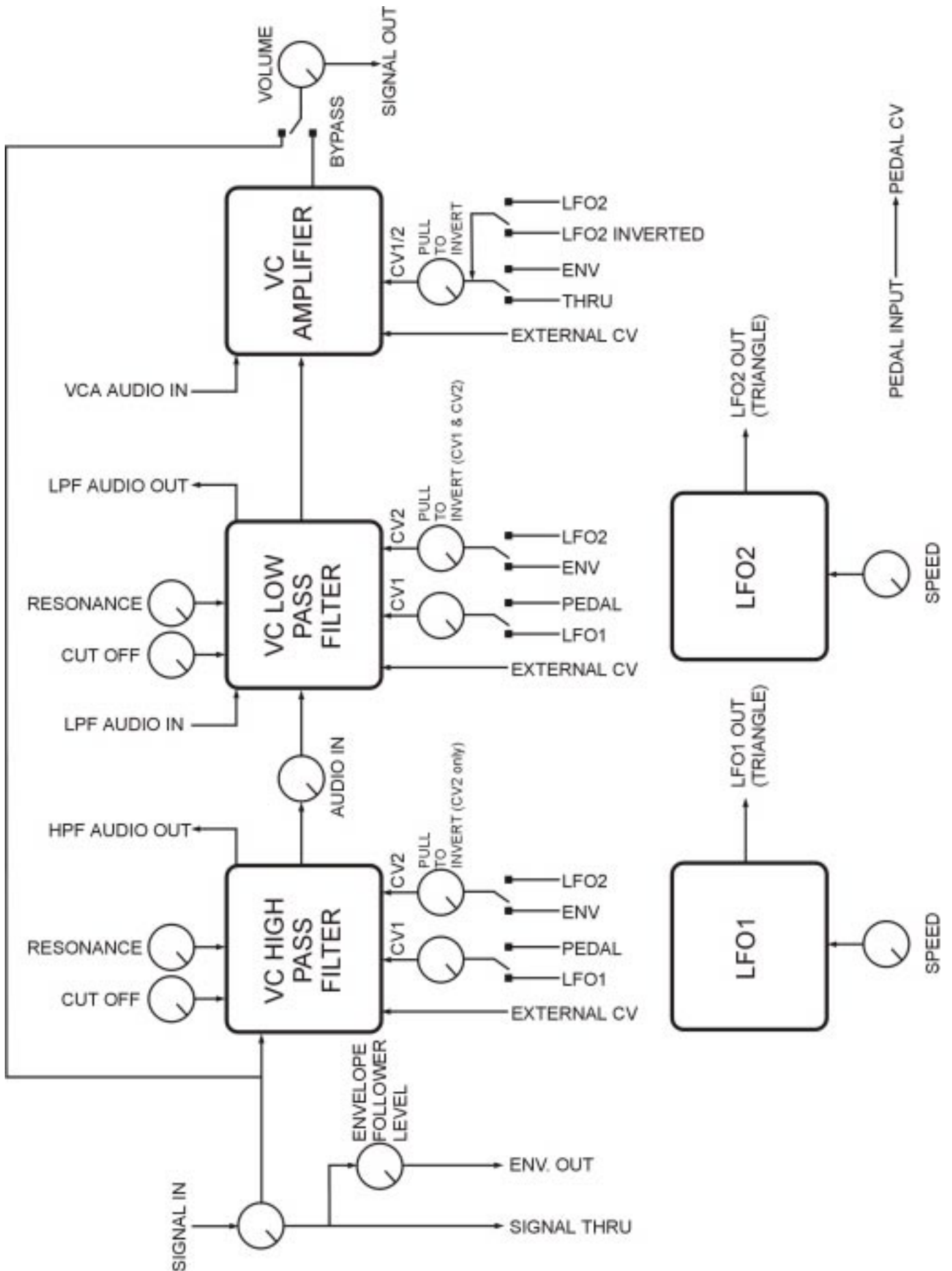

Controls In Detail

INPUT LEVEL

This control sets the input level of the signal fed into the Audio In socket. At higher settings it is possible to overload the input signal for a distorted sound if required.

ENVelope FOLIoW LEVEL

This control sets the sensitivity of the Envelope Follower. At higher settings, a larger ENV follower signal will be obtained.

LFO1 SPEED / LFO2 SPEED

These controls set the 2 LFO frequencies.

High Pass Filter

RESOnance

This control sets the resonance level. A higher setting increases the intensity of the resonance. At very high settings it is possible to self-oscillate the filter.

CV1 LEVEL

This control sets the amount the CV source selected via the switch will modulate the HPF cut-off frequency: The source switch has 3 options; LFO1 (up), Off/no signal (centre), PEDAL (down)

LFO1	LFO1 is used as the source
center	no signal is routed (no modulation effect)
PEDAL	if a CV pedal is being used, this is the source

CV2 LEVEL

This control sets the amount the CV source selected via the switch will modulate the HPF cut-off frequency. When this switch is pulled out, the CV source is inverted - so the positive signal is flipped over. This is ideal so you can have, for example, the LPF sweeping up whilst the HPF is sweeping down. The source switch has 3 options; Env (up), Off/no signal (centre), LFO2 (down)

ENV	The ENV follower is the source
center	no signal is routed (no modulation effect)
LFO2	LFO2 is used as the source

CUTOFF

This control sets the cut-off frequency. As the setting is increased, more and more lower frequencies are filtered out.

Low Pass Filter

RESOnance

This control sets the resonance level. A higher setting increases the intensity of the resonance. At very high settings it is possible to self-oscillate the filter.

CV1 LEVEL

This control sets the amount the the CV sources selected via the switch will modulate the HPF cut-off frequency. When this switch is pulled out, the CV source is inverted - so the positive signal is flipped over. This is ideal so you can have, for example, the LPF sweeping up whilst the HPF is sweeping down. The source switch has 3 options; LFO1 (up), Off/no signal (centre), PEDAL (down)

LFO1	LFO1 is used as the source
center	no signal is routed (no modulation effect)
PEDAL	if a CV pedal is being used, this is the source

CV2 LEVEL

This control sets the amount the CV source selected via the switch will modulate the HPF cut-off frequency. When this switch is pulled out, the CV source is inverted - so the positive signal is flipped over. This is ideal so you can have, for example, the LPF sweeping up whilst the HPF is sweeping down. The source switch has 3 options; ENV (up), Off/no signal (centre), LFO2 (down)

ENV	The ENV follower is the source
center	no signal is routed (no modulation effect)
LFO2	LFO2 is used as the source

CUTOFF

This control sets the cut-off frequency. As the setting is increased, more and more higher frequencies are filtered out.

AUDIO IN LEVEL

This control sets the audio in level to the LPF (following the output of the HPF). This control must not be at zero to hear some effect. In normal use leave it at maximum. Use it to adjust the audio in level when using the LPF Audio In socket on the rear panel.

VCA

Bypass Switch

The filter effects can be switch in (IN) or out (BYPassed). This allows you to compare the unprocess input signal and the final processed signal for comparison.

IN (switch up)

The effect is switch IN. The signal at the output socket is the processed signal.

BYPass (switch down)

The input signal is directly routed to the output signal and the filters have no effect. The processor is literally bypassed.

To hear any effect of the filters/VCA the switch must be at the IN position.

CV1/2 LEVEL

This control sets the amount the CV1/2 sources selected via the switches will modulate the VCA level.

The CV1 source switch has 3 options; ENV (up), Off/no signal (centre), LFO1 (down)

ENV	The ENV follower is the source
center	no signal is routed (no modulation effect)
THRU	The VCA is held open at a level near full volume

The CV2 source switch has 3 options; LFO2 (up), Off/no signal (centre), inverted LFO2 (down)

LFO2	LFO2 is used as the source
center	no signal is routed (no modulation effect)
-LFO2	LFO2 is inverted and used as the source

To hear any processed signal at the output socket, the VCA must be active by applying CV. The CV 1/2 LEVEL control must be used in conjunction with the CV source switched.

OUTPUT VOLUME

This control sets the final main output level.

CV Signal Inverters

HPF CV Level 2, LPF CV Level 1 and LPF CV Level 2 all have built in push-pull on/off switched. When the knob is pulled out, the CV signal is inverted (up-side-down).

This is a useful feature for when you want the LPF and HPF sweeping in opposite directions when using the same CV source.

For example, if LFO2 is the source for CV modulation of the 2 filters, if the LPF CV Level knob is pulled out, then as the HPF sweeps up, the LPF will sweep down.

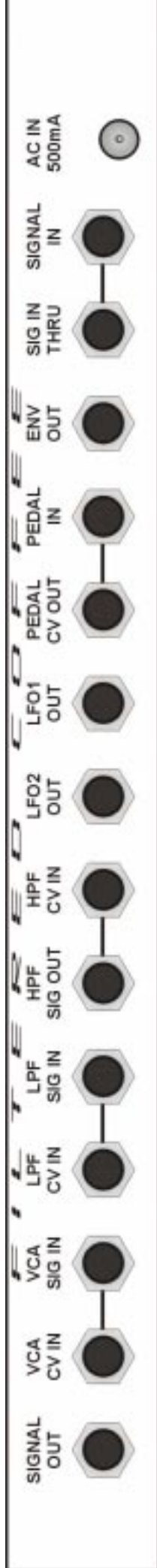

Rear Panel

Connectors as view from the rear, right to left. The Filtered Coffee provides un-unusually high number of connection sockets, more commonly associated with modular synthesisers. The maximum amount of connectivity, space allowing, has been supplied for maximum flexibility.

POWER IN

This unit requires a 15 volt AC signal (not DC!). 500mA minimum. Although the unit requires AC, the type of plug required is called a '2.1mm DC plug'.

All jack sockets are 6.35mm mono, except the Pedal Input socket which is a stereo type.

SIGNAL IN

Plug your audio in here. The input will take line level and guitar level signals without the need for pre-amp. A mic' source may need to be pre-amp'ed.

SIGNAL IN THRU

This is a direct copy of the input signal, which is made available to be fed through to other Filtered Coffee's or other processors. Two Filtered Coffees can be connected up for stereo use. Note the signal is unbuffered.

ENVELOPE OUT

The envelope follower CV signal is available here.

PEDAL IN

Plug the optional CV pedal in here. There are notes later if you wish to source your own pedal.

PEDAL CV OUT

The Pedal signal is turned into a useable CV and is available here. The range is 0 to 12V.

LFO1 OUT

The LFO1 CV signal is available here.

LFO2 OUT

The LFO2 CV signal is available here.

HPF CV IN

The HPF cut-off can be controlled via an external CV using this socket. Range is -12 to +12V.

HPF SIGNAL OUT

The signal filtered by the HPF is available here, before is is further filtered by the LPF.

LPF SIGNAL IN

If you wish to feed a signal through the LPF/VCA only, bypassing the HPF, use this socket.

LPF CV IN

The LPF cut-off can be controlled via an external CV using this socket. Range is -12 to +12V.

VCA SIGNAL IN

If you wish to feed a signal through the VCA only, bypassing both filters, use this socket.

VCA CV IN

The VCA level can be controlled via an external CV using this socket. Range is -12 to +12V.

SIGNAL OUT

The processed signal is available here. (Unprocessed if the Bypass switch is set to BYP.

Optional CV Pedal

Introduction

The FC features a CV pedal input. A special kind of variable level foot pedal can be used to produce a variable CV. The CV range is 0 to 12V. The signal can be routed to various modulation destinations via the front panel switches.

The pedal is ideal for hands free control, i.e. guitarists!

Use

Connect the CV pedal to CV PEDAL IN on the rear panel.

As the pedal is push forwards, the voltage will increase.

The optional pedal we can supply is made of very durable plastic and will suit most musicians. However, we have yet to see whether it will withstand unreasonable stomping from heavy metal guitarists!

Any CV pedal that is terminated with a stereo 6.35mm jack plug, and with the correct internal wiring can be used.

The stereo 6.35mm pedal jack plug must have the potentiometer wiper on the tip as shown in the diagrams below.

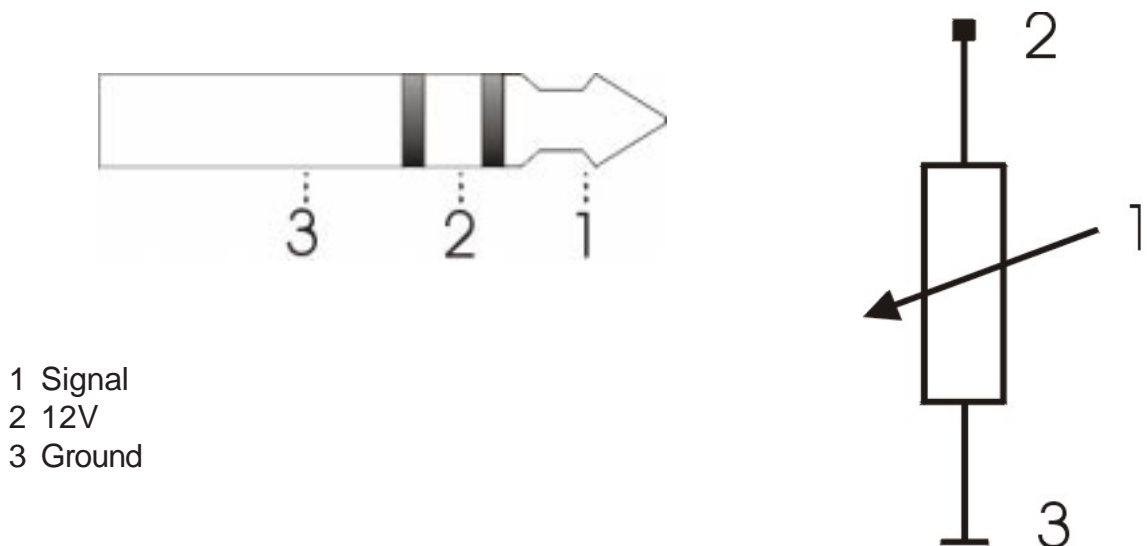

Description of sections

ENV FOLW (Envelope Follower)

An envelope follower is a circuit that takes an audio input signal, and produces an output control voltage that represents the amplitude of the audio input.

This would generally be used so that a VCA level could be controlled by the audio input level. It can also be used to control the filter cut-off.

The CV LEVEL control will set how sensitive the follower is to the input level. The follower LED will indicate when it reacts to a signal.

LFO

A Low Frequency Oscillator is a circuit that produces a repeating waveform. The unit has 2 independent LFO's each outputting a triangle waveform voltage. The signal can be used to sweep the filters up and down., or to add tremelo to the output level.

VCA

The Voltage Controlled Amplifier is a device that controls the level or volume of a signal via a voltage. This way the output level of the unit can be varied with a LFO or cv pedal. If the VCA is not modulated by any CV, or it is not switched to THRU, no signal will be heard as the volume will be zero.

HPF

The High Pass Filter is a circuit that will only let high frequencies through it. It filters out the lower frequencies. The point at which the lower frequencies are filtered is set by the cut-off frequency. The roll-off is 12db/oct.

LPF

The LowPass Filter is a circuit that will only let low frequencies through it. It filters out the higher frequencies. The point at which the higher frequencies are filtered is set by the cut-off frequency. The roll-off is 12db/oct.

Together, the LPF and HPF can be combined to be a Band Pass Filter (BPF). This means a band of frequencies are passed through, filtering out the lower and higher frequencies, passed the cut-off points set by the two CUTOFF controls.

Certain combined settings of the LPF and HPF may result in no output signal. This is because we have not restricted the ranges of the two filters, so it is possible to filter out all the signal. The controls are unrestricted to allow maximum flexibility.

Filtered Coffee 'user manual'
part of the Phobos range by Analogue Solutions

web: www.analoguesolutions.com

email: fc@analoguesolutions.com

tel/fax: +44 (0) 1384 35 36 94

post: 56 kingsley road, kingswinford, dy6 9rx, uk

PHOBOS FC e&oe (c) 5-2002