

**572 SPL Computer**



**572**

**User's Guide**

## Table of Contents

---

|                   |   |    |
|-------------------|---|----|
| <i>Chapter 1</i>  | Introduction                                | 1  |
| <i>Chapter 2</i>  | Operator Safety Summary                     | 3  |
| <i>Chapter 3</i>  | Setup                                       | 4  |
|                   | Calibration Checklist                       | 6  |
| <i>Chapter 4</i>  | Front & Rear Panel Overview                 | 7  |
| <i>Chapter 5</i>  | 572 Basics                                  | 10 |
| <i>Chapter 6</i>  | Technical Tutorial                          | 12 |
| <i>Chapter 7</i>  | Using the 572                               | 15 |
| <i>Chapter 8</i>  | Applications                                | 23 |
| <i>Chapter 9</i>  | Troubleshooting                             | 25 |
| <i>Chapter 10</i> | Specifications                              | 26 |
| <i>Chapter 11</i> | Warranty & Service                          | 27 |
| <i>Appendix A</i> | External Sensing & Multi-Unit Installations | 29 |
| <i>Appendix B</i> | Connections                                 | 31 |

Rev A.00, 24 February, 1999

Symetrix part number 53572-0A00

Subject to change without notice.

©1999, Symetrix, Inc. All right reserved.

Symetrix is a registered trademark of Symetrix, Inc.

Mention of third-party products is for informational purposes only and constitutes neither an endorsement nor a recommendation. Symetrix assumes no responsibility with regard to the performance or use of these products.

Under copyright laws, no part of this manual may be reproduced or transmitted in any form or by any means, electronic or mechanical, including photocopying, scanning, recording or by any information storage and retrieval system, without permission, in writing, from Symetrix, Inc.

 **Symetrix**

14926 35th Ave. West  
Lynnwood, WA 98037 USA

Tel (425) 787-3222

Fax (425) 787-3211

Email [symetrix@symetrixaudio.com](mailto:symetrix@symetrixaudio.com)

# 572

 **Symetrix**

The Symetrix 572 SPL Computer is an automatic level controller that maximizes intelligibility by changing gain in proportion to environmental noise level changes; in essence, controlling the volume of the background/paging system by measuring the volume of the ambient noise and then adjusting the system gain accordingly. Unique to the 572 is its ability to utilize the sound system’s loudspeakers as noise measurement transducers, in place of the usual microphones. The 572 switches the speaker line from the amplifier’s output to its own sensing input. In less than one second it reads the ambient noise level and switches the speaker line back to the amplifier. Special impedance matching, frequency shaping, and level shifting circuits allow the 572 to acquire precise relative noise measurements from virtually any speaker line, with any number of speakers of any impedance, transformer coupled or direct coupled, 25V or 70V.

The operating characteristics of the SPL computer are controlled by a powerful microprocessor, running under Symetrix proprietary software. This reduces the 572’s calibration time and allows the installer to optimize performance for any situation. No test gear is needed because the 572 obtains and stores the information it needs during calibration.

The 572 has separate inputs for paging and music as well as a direct paging microphone input. Both the speakers and the amplifiers connect directly to the 572. A front panel page over music function enables up to 14 dB of music attenuation during announcements. There are multiple option switches for telling the 572 how to treat the page/music signal as well as how to react to changes in the acoustic environment. The LED meter on the front not only indicates gain change but also aids in setup and calibration and identifies errors.

You show the 572 the parameters of the acoustic environment during calibration and then set the way you want the unit to respond to changes. The 572 then takes the information it has stored in memory and makes smooth, appropriate changes to keep the levels exactly where you want them. In order for the speakers to act as loudspeakers and sensors, there must be times when no audio is passing through the speakers to allow the sample of the ambient noise to be taken. Thus the 572 takes advantage of silent periods in the paging or music to take a sample, or it forces a sample based on the front panel setting at timed intervals. The 572 will unobtrusively fade out the music, take a sample, and then fade the music back in, all in a matter of seconds. The 572 will not, however, interrupt any signal that appears at the page input, thus keeping the unit from forcing a sense period during a page.

From malls to restaurants to factories, the Symetrix 572 gives you effective, reliable, system level control without an operator or the normal additional costs.

Feel free to contact us if you have questions, comments, or suggestions:

- Phone: (425)787-3222
- Fax: (425)787-3211
- Email: [symetrix@symetrixaudio.com](mailto:symetrix@symetrixaudio.com)
- Website: [www.symetrixaudio.com](http://www.symetrixaudio.com)

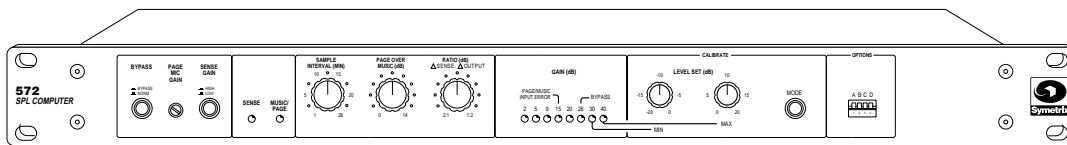

Front panel

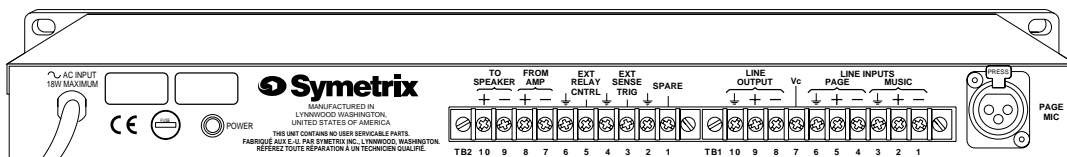

Rear panel



## Do You Have The Right Unit?

Symetrix makes two different SPL computers: the 571 and the 572. Although both units perform essentially the same task, they are different.

The 571 requires an external sensing microphone(s) to monitor ambient conditions. The 571 works in real time; adjustments are made continuously, regardless of music, paging, or silence. The 571 **does not** interrupt the signal path at any time.

The 572 uses the sound system loudspeaker(s) to monitor ambient conditions. Doing this requires the 572 to monitor the incoming program material for silent sections. Once the 572 detects silence, it switches to sense mode, switching the loudspeaker(s) from the amplifier output to its sense input. Sensing takes one to two seconds. Any signal applied to the paging inputs during this time immediately terminates the sense period. If a silent period never occurs, the 572 forces one. A front-panel control determines the length of time that elapses before a forced sense occurs. Sensing may also be triggered externally. The 572 **interrupts** the signal path during sensing. Table 1-1 provides a tabular comparison of the two units.

| <u>Feature</u>   | <u>571</u> | <u>572</u> |
|--|------------|------------|
| Uses dedicated microphone for ambient sensing .....                | Y          | N          |
| Uses sound system speakers for ambient sensing .....               | N          | Y          |
| Sound system loudness controlled by ambient noise conditions ..... | Y          | Y          |
| Continuous, real time operation .....                              | Y          | N          |
| Program silence sensing triggers ambient sense period .....        | N          | Y          |
| Mic and line level paging inputs .....                             | Y          | Y          |
| Page over music (ducking) .....                                    | Y          | Y          |
| Music + page mixing .....  | Y          | Y          |
| Calibration required .....   | Y          | Y          |
| Timed ambient sensing .....  | N          | Y          |
| Interrupts signal path during sensing .....                        | N          | Y          |

Table 1-1. 571 - 572 Feature comparison.

# 572

## Equipment Markings

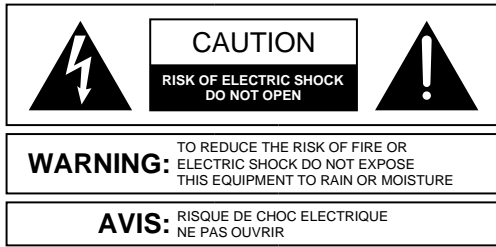

SEE OWNERS MANUAL. VOIR CAHIER D'INSTRUCTIONS.  
 No user serviceable parts inside. Refer servicing to qualified service personnel.  
 Il ne se trouve a l'interieur aucune piece pouvant etre reparaee l'usager.  
 S'adresser a un reparateur competent.

The lightning flash with arrowhead symbol within an equilateral triangle is intended to alert the user of the presence of uninsulated “dangerous voltage” within the product’s enclosure that may be of sufficient magnitude to constitute a risk of electric shock to persons. The exclamation point within an equilateral triangle is intended to alert the user of the presence of important operating and maintenance (servicing) instructions in the literature accompanying the product (i.e. this manual).

**Caution** *To prevent electric shock, do not use the polarized plug supplied with the unit with any extension cord, receptacle, or other outlet unless the blades can be fully inserted.*

## Terms

Several notational conventions are used in this manual. Some paragraphs may use **Note**, **Caution**, or **Warning** as a heading. Certain typefaces and capitalization are used to identify certain words. These are:

|                 |   |
|-----------------|---|
| <b>Note</b>     | Identifies information that needs extra emphasis. A <b>Note</b> generally supplies extra information to help you to better use the 572. |
| <b>Caution</b>  | <i>Identifies information that, if not heeded, may cause damage to the 572 or other equipment in your system.</i>                       |
| <b>Warning</b>  | <b>Identifies information that, if ignored, may be hazardous to your health or that of others.</b>                                      |
| <b>CAPITALS</b> | Controls, switches or other markings on the 572’s chassis.  |
| <b>Boldface</b> | Strong emphasis.  |

## Important Safety Instructions

Please read and keep these instructions. Heed and follow all warnings and instructions. Install in accordance with the manufacturer’s instructions.

**Power Source** This product is intended to operate from a power source that does not apply more than 250V rms between the power supply conductors or between either power supply conductor and ground. A protective ground

connection, by way of the grounding conductor in the power cord, is essential for safe operation.

**Grounding** The chassis of this product is grounded through the grounding conductor of the power cord. To avoid electric shock, plug the power cord into a properly wired receptacle before making any connections to the product. A protective ground connection, by way of the grounding conductor in the power cord, is essential for safe operation. **Do not defeat the safety purpose of the grounding plug.** The grounding plug has two blades and a third grounding prong. The third prong is provided for your safety. When the provided plug does not fit your outlet, consult an electrician for replacement of the obsolete outlet.

**Danger from Loss of Ground** If the protective ground connection is lost, all accessible conductive parts, including knobs and controls that may appear to be insulated, can render an electric shock.

**Proper Power Cord** Use only the power cord and connector specified for the product and your operating locale. Use only a cord that is in good condition. **Protect the power cord** from being walked on or pinched, particularly at plugs, convenience receptacles, and the point where they exit from the apparatus.

**Proper Fuse** The user accessible fuse is a part of the attached AC connector. The fuseholder accepts 5 x 20mm diameter fuses. For 117VAC operation, the correct value is 0.5A, 250VAC, standard. For 230VAC operation, the correct value is 0.25A, 250VAC, standard.

**Operating Location Do not operate this equipment under any of the following conditions:** explosive atmospheres, in wet locations, in inclement weather, improper or unknown AC mains voltage, or if improperly fused. Do not install near any heat source such as radiators, heat registers, stoves, or other apparatus (including amplifiers) that produce heat. Unplug this apparatus during lightning storms or when unused for long periods of time.

**Stay Out of the Box** To avoid personal injury (or worse), do not remove the product covers or panels. Do not operate the product without the covers and panels properly installed. Only use accessories specified by the manufacturer. Clean only with a damp cloth.

**User-serviceable parts** There are no user serviceable parts inside the 572. In case of failure, refer all servicing to the factory. Servicing is required when the 572 has been damaged in any way, such as when a power supply cord or plug is damaged, liquid has been spilled or objects have fallen into the apparatus, the apparatus has been exposed to rain or moisture, does not operate normally, or has been dropped.

572

## What You'll Need

---

To install a 572, you'll need the following items:

1. The 572.
2. Access to the power amplifier input (line level), mixer output (line level), power amplifier output (speaker level), speaker line connections.
3. Background music feed (usually the mixer line output).
4. Paging feed (line or mic level or both) preferably separate from the background music feed.
5. A time where the ambient noise level in the loudspeaker coverage area is at its normal minimum. This is the level at which the 572 begins raising the level. Thus, it should NOT be when the space is dead quiet, unless that is the normal minimum.
6. Program audio and paging signals during calibration.

## Overview

---

The following points of information must be considered during system design and installation.

### **Place the 572 in the signal chain as the final level controlling device.**

Equalizers following the 572 are acceptable IF their controls (both EQ and level) will not be changed after calibration. It is imperative that any gain or level controls used in the signal chain after the 572 remain unchanged once the unit has been calibrated. This includes wall mounted autoformer and L-pad speaker-level controls used for zone balancing. Level controls in the signal chain before the SPL Computer are acceptable, because the unit "reads" input level changes.

### **Calibrate the 572 when the coverage zone's ambient noise level is its nominal minimum.**

"Nominal minimum" means whatever ambient noise level is the minimum for that particular environment, no matter what the actual level may be. It should not be dead silent unless that is normal. The ambient noise level measured by the 571 during the calibration procedure is used by the microprocessor to calculate gain changes. As a result, the unit doesn't care what the actual ambient noise level is during calibration. However, the overall control range may be inadequate if the noise level is too high during calibration.

### **During calibration, run normal program signals through the system.**

This allows the SPL Computer to develop an acoustical performance history of the environment based upon the type of material that will ordinarily be run through the system. No extra test equipment is required for normal calibration. However, to set the system up for specific operating levels, a noise source and SPL meter are needed.

## Pre-installation Considerations

---

Before installing the 572, be sure that you've considered the following items:

1. Ambient noise sources in the loudspeaker coverage area. Are there any noise sources near any of the speakers used for sensing?
2. It is not necessary to use all speakers for sensing.
3. If the speakers are wired using the "home run" method<sup>1</sup>, then you'll have extra flexibility in excluding specific speakers from the speakers used for ambient sensing (if needed).
4. The speaker wiring should be separate from any AC or other EMI-noisy wiring. Neither side of the wiring can be grounded, except at the amplifier.
5. Horn speakers may require modification of the 572, especially if the ambient noise level is high.
6. There can be no user adjustable level controls in the speaker lines.
7. Once calibrated, it is not permissible to alter the settings of any level controls that are electrically located after the 572.

<sup>1</sup>The home run method of wiring brings each speaker (or sometimes a subgroup of speakers) to the amplifier on its own pair of wires. The usual method is to wire from speaker to speaker, which saves wire at the expense of flexibility.

# 572

8. If there are multiple loudspeaker zones, there probably ought to be a separate 572 for each zone.
9. If the power amplifier is larger than 300 watts (70-volt systems), 200 watts (8-ohm systems), or 100 watts (4-ohm systems), then the internal 5-amp relay can't handle the load current. You must use an external relay.
10. It is good to know the minimum and maximum ambient levels (dB SPL) that the system is expected to handle. Of course, the sound system should be able to exceed the maximum ambient by 3-6 dB (unless it's in the design that the system can't out-shout the crowd).
11. It's preferable that the 572 mix the paging signals with the background music or other signals internally through its separate paging and music inputs (as opposed to supplying the 572 with a mix of everything). The 572 monitors its paging inputs and immediately terminates a sense period when a paging signal is present. This is not true for the music input.
12. Loudspeakers from "alien" systems (sound systems located within the sensing zone of the 572, but not under control of the 572) can cause unwanted gain changes.

## Connections

A drawing of a typical music with paging system is shown in below. Make all of the following connections:

1. Paging microphone (or mic-level mixer output) to the **PAGE Mic** XLR connector. Remember that mic or line paging sources duck the signal connected to the **MUSIC** input.
2. Line-level paging source (or other source) to the **PAGE** terminals on TB1. Remember that mic or line paging sources duck the signal connected to the **MUSIC** input.
3. Background or foreground music source to the **MUSIC** terminals on TB1. Signals connected to this input are ducked (attenuated) by signals present on either of the **PAGE** inputs.
4. SPL Computer output from TB1 to your sound system's amplifier(s).
5. Your sound system's amplifier output to the 572's **FROM AMP** terminals on TB2.
6. The speaker output of the 572 to the sound system speakers in the controlled zone.

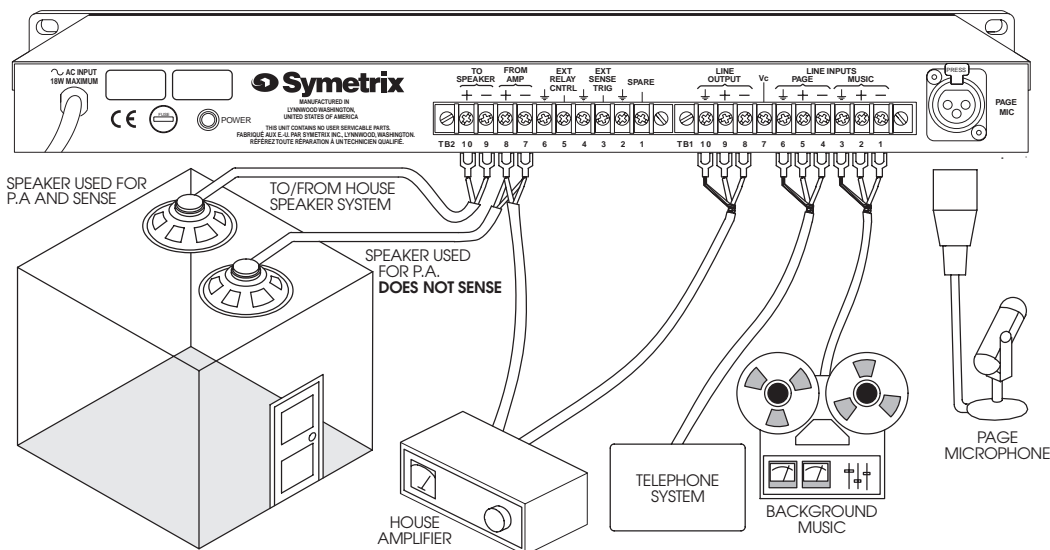

Figure 3-1. 572 generic hookup diagram.

**Caution** Failure to connect the 572 to the proper ac mains voltage may cause fire and/or internal damage. There are no user serviceable parts inside the chassis. Refer all service to qualified service personnel or to the factory.

**Warning** Lethal voltages are present inside the chassis. There are no user serviceable parts inside the chassis. Refer all service to qualified service personnel or to the factory.

---

## Calibration Settings Table

---

Set the controls and switches on the front and rear panel as shown below.

| <u>Front Panel Control</u> | <u>Setting</u> | <u>Rear Panel</u> | <u>Setting</u>  |
|----------------------------|----------------|-------------------|---|
| <b>BYPASS</b> switch       | out (NORM)     | <b>OUTPUT</b>     | Connect to power amplifiers.                          |
| <b>PAGE MIC</b> gain       | 12:00 o'clock  | <b>PAGE MIC</b>   | Connect balanced, low-impedance page microphone here. |
| <b>SENSE GAIN</b> switch   | out (HIGH)     | <b>MUSIC IN</b>   | Connect line-level music source here.                 |
| <b>SAMPLE INTERVAL</b>     | 8:00 o'clock   | <b>PAGE IN</b>    | Connect line-level paging source here.                |
| <b>PAGE OVER MUSIC</b>     | 8:00 o'clock   |                   |   |
| <b>RATIO</b>               | 12:00 o'clock  |                   |   |
| <b>LEVEL SET MIN</b>       | 9:00 o'clock   |                   |   |
| <b>LEVEL SET MAX</b>       | 8:00 o'clock   |                   |   |
| <b>OPTION</b> switches     | All down       |                   |   |

## Calibration Checklist

---

You initiate the calibration procedure by pressing the **MODE** switch once (from **OPERATE** mode). Complete the following checklist before beginning the calibration procedure.

- Complete all input and output connections.
- Apply power to the 572.
- Verify that the unit passes signal in the **BYPASS** mode. Enter **BYPASS** mode by depressing the **BYPASS** switch. Return the **BYPASS** switch to the **OUT** position. You should still have audio.
- Set Option switch B to the **UP** position (sense view). Observe the LED bargraph. There should be at one LED on, up to a maximum of 7 LEDs on. If no LEDs are on, depress the **SENSE GAIN** switch. Leave the switch in whatever position results in a reading between the first and last LEDs in the bargraph.
- Set the front and rear panel controls as shown in Calibration Settings Table (previous page).

**Caution** *The 572 resistively mixes its line inputs in Bypass mode. This can cause attenuation whose amount depends upon the actual source devices as well as the amplifier(s) connected to the unit's outputs.*

*The 572 delivers unity gain when the output is operated unbalanced, and the gain is +6 dB when the output is operated balanced.*

## Calibration Procedure

---

1. Apply program or paging signals to the 572's input(s).
2. Press the **MODE** switch once to enter **CALIBRATION** mode.
3. Using the 572's **LEVEL SET MIN** control, adjust the control for the minimum desired operating level when the LED bargraph indicator marked **SET MIN** flashes.
4. Using the 572's **LEVEL SET MAX** control, adjust the control for the maximum desired operating level when the LED bargraph indicator marked **SET MAX** flashes.

The 572 "listens" to the sound system for about 8 seconds at the minimum level (after it detects the last adjustment of the **MIN** control), and then for about 8 seconds at the maximum level (after the last adjustment of the **MAX** control). Then the microprocessor returns the unit to **OPERATE** mode under the new calibration values.

When the calibration procedure is completed, the acoustic performance record of the room is placed in nonvolatile memory along with the minimum and maximum level settings. The unit will operate under these calibration settings until the calibration procedure is run again.

The calibration procedure may be run as many times as necessary. If for any reason the procedure is interrupted before completion, the unit returns to operate mode under the previously stored values. If the procedure is run to completion with no changes, the unit calculates the same values as it did under the previous calibration procedure, and puts those new values into nonvolatile memory. Only when the level set max or **LEVEL SET MIN** setting is changed does the unit put new operating values into memory. You can force sensing by turning the sample interval control to 1 and then quickly returning it to 5. You can also force sensing by using option switch D and TB2-3.

# 572



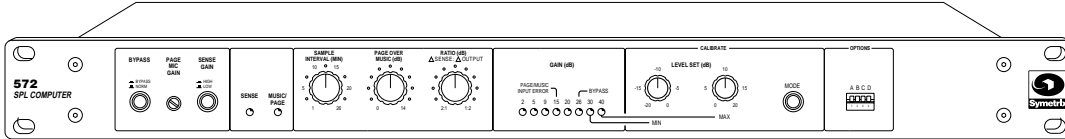

Front Panel Overview

| Feature                       | Description  |
|-------------------------------|--|
| <b>BYPASS</b> switch          | When depressed, resistively mixes the line level music and page inputs and hardwires them to the output terminals. The 572 will pass signal regardless of it's operational status.   |
| <b>PAGE MIC GAIN</b> trimpot  | Screwdriver adjust level control provides up to 26 dB attenuation of signals from the page mic input.  |
| <b>SENSE GAIN</b> switch      | Determines the gain of the sense preamp. When the switch has been depressed, the sense preamp's gain is 40dB higher. Use option switch B to help you determine the correct setting for this switch.  |
| <b>SENSE</b> LED              | Indicates that the 572 is sensing the ambient conditions in the controlled area.   |
| <b>MUSIC/PAGE</b> LED         | Indicates that the 572 is in its music/page mode.  |
| <b>SAMPLE INTERVAL</b>        | This control sets the time period between forced samples to compute sound pressure level changes. If the 572 takes a silence-caused sample during this time period, the sample interval timer is reset. If the incoming program material has enough silent periods, forced sampling will never occur. This control is disabled in external trigger mode.                                   |
| <b>PAGE OVER MUSIC</b>        | Determines how much music signals are attenuated (ducked) during paging, from 0 to 15 dB.  |
| <b>RATIO: ΔSENSE: ΔOUTPUT</b> | Sets the ambient gain ratio: from 2:1 to 1:2. This determines whether the 572 makes a smaller change than the ambient (2:1) or a larger change than the ambient (1:2).   |
| <b>GAIN</b> LED display       | LED bargraph that indicates the amount of gain being added to the sound system by the 572. In cal mode, the display serves as an error-condition indicator and as a prompting device.  |
| <b>LEVEL SET MIN</b> control  | Active only during calibration; sets the minimum operating level of the sound system: from 0 to -20 dB.  |
| <b>LEVEL SET MAX</b> control  | Active only during calibration; sets the maximum operating level of the sound system: from 0 to +20 dB.  |
| <b>CALIBRATE</b> switch       | Momentary switch alternates the 572's mode from operate to calibrate. Operate is the initial power-up state, and is indicated during use by the LED display showing gain change and either the sense or music/page LED being activated. Depressing the CALIBRATE switch once alternates states to calibration mode as indicated by flashing SET MIN indicator on the LED bargraph display. |
| <b>OPTIONS DIP</b> switch     | These four switches allow several of the 572's operating parameters to be adjusted.  |



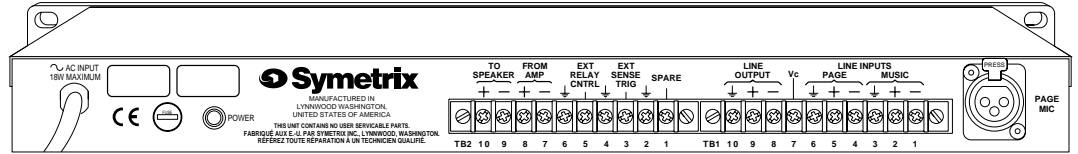

## Rear Panel Overview

| <u>Feature</u>        | <u>Description</u>  |
|-----------------------|---|
| <b>SERIAL NUMBER</b>  | [Please send in the completed warranty card.]   |
| <b>AC POWER INPUT</b> | Power cord. Connect only to appropriate AC power source. Refer to rear-panel marking for correct AC source value.   |
| <b>FUSE</b>           | AC mains fuse. Replace only with same type of fuse, as noted on the rear of the chassis. <i>Domestic</i> : 1/4A, 250V ac, fast blowing (Bussman type AGC-1/4) <i>Export</i> : 1/8A, 250V ac, fast blowing (Bussman type GDA-125mA).   |
| <b>PAGE MIC INPUT</b> | Balanced, mic level input for paging microphone. Phantom powering is not present. If using a phantom powered microphone, ensure that the phantom voltage does not exceed 15V. Higher voltages may be used if the powering device contains blocking capacitors or isolation transformers to prevent the phantom supply voltage from appearing at the mic input of the 572. |

# 572

---

## Terminal Strip Connections

---

| <u>Feature</u>  | <u>Term.#</u> | <u>Description</u>  |
|-----------------|---------------|---|
| TO SPEAKER      | TB2(10,9)     | Connect speakers used for sensing and sound system usage here. Speakers may be speaker impedance or constant voltage.   |
| FROM AMP        | TB2(8,7)      | Connect amplifier here. Amplifier output may be speaker impedance or constant voltage.  |
| GROUND S        | TB2(6,4,2)    | Connect to circuit ground inside the 572.   |
| EXT RELAY CNTRL | TB2(5)        | NPN open collector output for driving external relay. You must supply power for the relay coil. Remember to connect a diode across the relay coil to absorb the back EMF generated by the relay coil. The maximum voltage at this point is 40 V dc at 625 mA.   |
| EXT SENSE TRIG  | TB2(3)        | Active low input. When option switch D is up, grounding this terminal forces a sense operation. The unit remains in sense mode for as long as this terminal is grounded. The terminal must remain grounded for at least one second in order to perform sensing. |
| SPARE           | TB2(1)        | Not used, not connected.  |
| GROUND S        | TB1(10,6,3)   | Connect to circuit ground inside the 572.   |
| LINE OUTPUT     | TB1(9,8)      | Balanced (differential) output of the 572.<br>For unbalanced usage, use TB1(9) and TB1(10). TB1(8) should float.  |
| V <sub>C</sub>  | TB1(7)        | Monitor point for the control voltage for the VCA. The gain relationship is -159mv/dB. Use this voltage to verify that the VCA is actually being told to change the gain or to connect a stereo-slave unit.   |
| PAGE INPUT      | TB1(5,4)      | Balanced line-level input for paging signals. Signals at these terminals cause signals applied to the music inputs to attenuate (duck). For unbalanced signals, use TB1(5) for signal and connect TB1(6,4) to ground.   |
| MUSIC INPUT     | TB1(2,1)      | Balanced line-level for music signals. Normally used for background music. Signals applied to these terminals are attenuated (ducked) whenever signals are present at either of the page inputs.  |

# 572

An SPL computer periodically samples the ambient sound in a room. Having this information, the SPL computer uses a combination of historical data and information stored during the unit's initial calibration to determine the optimum gain setting for the sound system.

### How Does It Work?

---

The 572 uses the combination of analog circuitry and digital circuitry under the control of a microprocessor. The microprocessor excels at following a set of instructions and making decisions. Since really high-performance digital audio circuitry is still quite expensive, the 572 uses a recording studio-quality voltage-controlled-amplifier (VCA) to control audio levels.

In operation, the 572 monitors its input signals for silence. Anytime that silence occurs (an option switch allows changing the silence threshold), the 572 switches to sense mode. In sense mode, the 572 reduces the amplifier input by at least 30 dB, the loudspeakers are disconnected from the power amplifier and connected to a high-gain differential amplifier (which cancels the hum and other junk picked up by the unshielded speaker wires). The 572's microprocessor monitors the output of the sense preamp and compares that signal to the calibration conditions stored in the 572's parameter storage RAM, and at the last sample period. Based on this information and the front-panel settings, the 572 decides how loud the sound system must operate to restore audibility.

The 572 also has an internal timer, controlled by the front-panel **SAMPLE INTERVAL** control that forces a sample if there haven't been any silent periods in the input signal. Anytime that the input signal causes a sample period, the timer resets. If the input material has sufficient silent periods, the timer-generated sample periods never occur.

In **CAL** mode, the 572 acquires a history of the environment's sonic behavior. The 572 takes three measurements: the environment's minimum level, the sound system's minimum level, and the sound system's maximum level. By running the system for about 8 seconds at the desired minimum and maximum sound pressure levels, the microprocessor remembers these three key performance parameters, which are automatically stored in nonvolatile memory.

During calibration, the installer sets minimum and maximum levels-the 572 "reads" the controls as they are changed, and stays in the appropriate calibration mode for about 8 seconds after the last change is made. This allows the installer time to reset operating levels as necessary.

When the system switches itself back to operate mode, the acoustical performance history acquired during calibration becomes the baseline for gain change decisions. In operate mode, the system goes about measuring environmental noise levels and internal signal levels. Because the computer has already committed to memory the parameters stored during calibration, it is able to predict the gain setting required.

### What About the Sensing Microphone?

---

Microphone? What microphone? The 572 doesn't use sensing microphones. It does use the sound system's loudspeakers as microphones during sensing. There aren't many constraints on your choice of loudspeakers. Horn-type speakers are more directional as well as being highly efficient (both as speakers and as microphones). We have found that planar-type speakers do not work well as microphones. Internally, the sense signal drives a bandpass filter (A-weighting approximation) before the 572 measures its level (strength).

572

---

## Where Should I Put the Sensing Microphone?

---

The sensing microphone needs to “hear” the ambient sound within the controlled space. In large spaces it may be better to only use a few of the sound system speakers for sensing. In the remainder of this manual, we’ll use the term “sensing speaker” to mean a speaker that is connected to the 572’s TO SPEAKER terminals that is used during sensing periods as a microphone.

## Where Shouldn’t I Put the Sensing Speaker(s)?

---

Avoid the following situations:

- Placing the sensing speaker(s) where it is within the noise field of a machine or other noise source, unless you want the source’s noise contribution to more or less control the level of the sound system. For example, how about a speaker in a newspaper plant near one of the printing press(es).
- Placing the sensing speakers where they always hear a nearby noise source. For instance, how about a shopping mall near the kiddie area. You can work around this by connecting these speakers to the TO AMP terminals so that they aren’t used for sensing.

## What Does the Ratio Control Do?

---

The **RATIO** control acts much the same as the ratio control on a compressor or expander: it affects the amount of change at the output for a given change at the input. In the 572, the **RATIO** control determines how much the output changes for a given change at the sense input. In the 12:00 position, the ratio is 1:1; a 1 dB sense change results in a 1 dB output change. Turning the **RATIO** control clockwise results in expansion: in the 1:2 position (full CW), a 2 dB change at the sense input results in a 4 dB output change. Turning the **RATIO** control counterclockwise results in compression: in the 2:1 position, a 2 dB sense input change results in only a 1 dB output change.

Use the **RATIO** control when you either want the 572 to more than keep up with the crowd (expansion), or when you want it to lag behind when the crowd is loud (compression). Another reason to use “compression” might be when the available amplifier power is limited. Last, you must decide whether or not you want the sound system to be capable of “out-shouting” the crowd.

## Remember

---

- Calibration must occur when the noise level in the controlled space is at it’s normal minimum (which may or may not be dead quiet).
- It helps if you have an estimate (SPL) of the maximum level required.
- The sound system must be capable of attaining the maximum level required.
- You can learn a great deal by listening to the sensing speakers. You’ll need an external microphone preamp to do this.
- You may need to create a second non-controlled zone to prevent the sound system level from changing in spaces where the ambient conditions are stable (rest rooms, elevators, break rooms, etc.)



Matching Levels vs Matching Impedances

In any audio equipment application, the question of “matching” inevitably comes up. Without digging a hole any deeper than absolutely necessary, we offer the following discussion to (hopefully) clarify your understanding of the subject.

Over the years, we have all had impedance matching pounded into our heads. This is important only for ancient audio systems, power amplifiers, and RF. Technically speaking, the reason is power transfer, which reaches a maximum when source and load are matched. Modern audio systems are voltage transmission systems and source and load matching is not only unnecessary, but undesirable as well.

Ancient audio systems operate at 600 ohms (or some other impedance value), and must be matched, both at their inputs and at their outputs. Generally speaking, if you are dealing with equipment that uses vacuum tubes, or was designed prior to 1970, you should be concerned about matching. These units were designed when audio systems were based on maximum power transfer, hence the need for input/output matching.

Power amplifiers are fussy because an abnormally low load impedance generally means a visit to the amp hospital. Thus, it’s important to know what the total impedance of the pile of speakers connected to the amplifier really is.

RF systems are matched because we really are concerned with maximum power transfer and with matching the impedance of the transmission line (keeps nasty things from happening). Video signals (composite, baseband, or otherwise) should be treated like RF.

Some folks seem to believe that balanced/unbalanced lines and impedances are related; or even worse that they are associated with a particular type of connector. Not so. Unbalanced signals are not necessarily high-impedance and balanced signals/lines are not necessarily low-impedance. Similarly, although 1/4-inch jacks are typically used for things like guitars (which are high-impedance and unbalanced), this does not predispose them to only this usage. After all, 1/4-inch jacks are sometimes used for loudspeakers, which are anything but high-impedance. Therefore, the presence of 3-pin XLR connectors should not be construed to mean that the input or output is low-impedance (or high-impedance). The same applies to 1/4-inch jacks.

So, what is really important? Signal level, and (to a much lesser degree), the impedance relation between an output (signal source) and the input that it connects to (signal receiver).

Signal level is very important. Mismatch causes either loss of headroom or loss of signal-to-noise ratio. Thus, microphone inputs should only see signals originating from a microphone, a direct (DI) box, or an output designated microphone-level output. Electrically, this is in the range of approximately -70 to -20 dBm. Line inputs should only see signals in the -10 to +24 dBm/dBu range. Guitars, high-impedance microphones, and many electronic keyboards do not qualify as line-level sources.

The impedance relation between outputs and inputs needs to be considered, but only in the following way:

**Always make sure that a device’s input impedance is higher than the output source impedance of the device that drives it.**

Some manufacturers state a relatively high-impedance figure as the output impedance of their equipment. What they really mean is that this is the minimum load impedance that they would like their gear to see. In most cases, seeing an output impedance figure of 10,000 (10K) ohms or higher from modern equipment that requires power (batteries or AC) is an instance of this type of rating. If so, then the input impedance of the succeeding input must be equal to or greater than the output impedance of the driving device.

Symetrix equipment inputs are designed to bridge (be greater than 10 times the actual source impedance) the output of whatever device drives the input. Symetrix equipment outputs are designed to drive 600-ohm or higher loads (600-ohm loads are an archaic practice that won’t go away). You don’t need to terminate the output with a 600-ohm resistor if you aren’t driving a 600-ohm load. If you don’t understand the concept of termination, you probably don’t need to anyway.



---

The two facts that you need to derive from this discussion are:

1. Match signal levels for best headroom and signal-to-noise ratio.
2. For audio, impedance matching is only needed for antique equipment and power amplifier outputs. In all other cases, ensure that your inputs bridge (are in the range of 2 to 200 times the output source impedance) your outputs.

## Signal Levels

---

The 572 is designed around studio/professional line levels: +4 dBu or 1.23 volts. The unit is quiet enough to operate at lower signal levels such as those found in semipro or musical-instrument (MI) equipment (-10 dBV or 316 millivolts).

## I/O Impedances

---

The 572 is designed to interface into almost any sound reinforcement application or background/foreground music application. This includes:

1. 600-ohm systems where input and output impedances are matched.
2. Unbalanced semiprofessional equipment applications.
3. Modern bridging systems where inputs are bridged and outputs are low source impedances (voltage transmission systems).

The 572's line input impedance is greater than 40k Ohms balanced, and greater than 40k Ohms unbalanced. The inputs may be driven from any source (balanced or unbalanced) capable of delivering at least -10 dBV into the aforementioned impedances.

## XLR Polarity Convention

---

The 572 uses the international standard polarity convention of pin 2 hot. The following chart shows the connections for each type of connector:

| <b>XLR</b> | <b>Tip-Ring-Sleeve</b> | <b>Signal</b> |
|------------|------------------------|---------------|
| 1          | Sleeve                 | Ground        |
| 2          | Tip                    | High          |
| 3          | Ring                   | Low           |

## Input and Output Connections

---

Appendix B illustrates how to connect the 572 to various balanced and unbalanced sources.

To operate the 572's balanced line inputs from unbalanced sources, run a 2-conductor shielded cable (that's two conductors plus the shield) from the source to the 572. At the source, connect the low/minus side to the shield, these connect to the source's ground; connect the high/plus side to the source's signal connection. At the 572, the high/plus wire connects to the screw terminal marked with a "+", the low/minus wire connects to the screw terminal marked with a "-", and the shield (always) connects to screw terminal marked GND. This is preferred as it makes best use of the 572's balanced input (even though the source is unbalanced). The other alternative shown in Appendix B converts the 572's balanced input into an unbalanced input at the 572's input terminals. This works, but is more susceptible to hum and buzz than the preferred method. There is no level difference either way.

We do not recommend unbalancing the 572's microphone inputs. Doing so makes these inputs considerably more susceptible to hum and induced noise.



---

## Condenser Microphones and the 572

---

The 572's paging microphone input is not equipped with phantom powering for condenser microphones. If you wish to use a phantom powered microphone you must provide a power source externally.

Note The microphone input is direct coupled: there are no dc blocking capacitors. If you use a phantom powered microphone, the phantom supply voltage must be 15 volts or less. (15 volts is the common-mode limitation of the microphone preamp.) If your particular microphone operates at a higher supply voltage than 15 volts the phantom power supply must dc-block its output using capacitors or a transformer.

# 572



This section is intended for more advanced users. If you are a first-time user, we recommend that you start out by using the procedure found in Chapter 3, “Setup.”

## Installation

The 572 may be installed freestanding or rack-mounted. Multiple unit installations require no additional breathing space between units.

### Installation Requirements

|                   |  |
|-------------------|--|
| <b>Mechanical</b> | One rack space (1.75 inches) required, 12.5 inches depth (including connector allowance).  |
| <b>Electrical</b> | 105-125 VAC, 18 Watts maximum.   |
| <b>Connectors</b> | Female XLR connectors and screw terminals for inputs. Pin 2 of the XLR connectors is “Hot.” Screw terminals for outputs and other connections. |

## Block Diagram

On the following page you will find the block diagram for the 572. Please take a moment and take note of the following:

- The balanced input amplifiers (mic and line) are direct coupled. This is only noteworthy if there is significant common-mode dc voltages present on the signal lines (greater than 15V). Phantom powering for condenser microphones falls into this category.
- The EXT RELAY CNTRL terminal is the open collector of a 2N4401 NPN transistor . You must supply power for any external relay used. The transistor’s limits are:  $V_{CEO} = 40V$  and  $I_{cmax} = 625\text{ mA}$ .
- In when the BYPASS switch is pressed, the line-level MUSIC and PAGE inputs are resistively mixed and sent to the outputs. There is no automatic hard-wire bypass in the event of a power failure.
- Paging signals (mic and line) are mixed and drive the ducker (PAGE OVER MUSIC) circuitry.
- The EXT SENSE TRIG input is not edge driven. The 572 remains in sense mode as long as this input is held low.
- Option switch B switches the LED bargraph to read the output of the sense preamplifier and forces the 572 into sense mode. This allows you to make sure that you have enough signal level for proper ambient sensing. The correct reading is more than one LED lit and less than all LEDs lit under all ambient conditions. The sense gain switch located on the front panel changes the gain of the sense preamp. Use either setting as long as the LED bargraph reads as described earlier.

The relay contacts used to switch the speakers to and from sense have a 5 ampere rating. If your load requires more current than this, use the EXT RELAY CNTRL terminal (TB2-5) to control an external high-current relay.

# 572

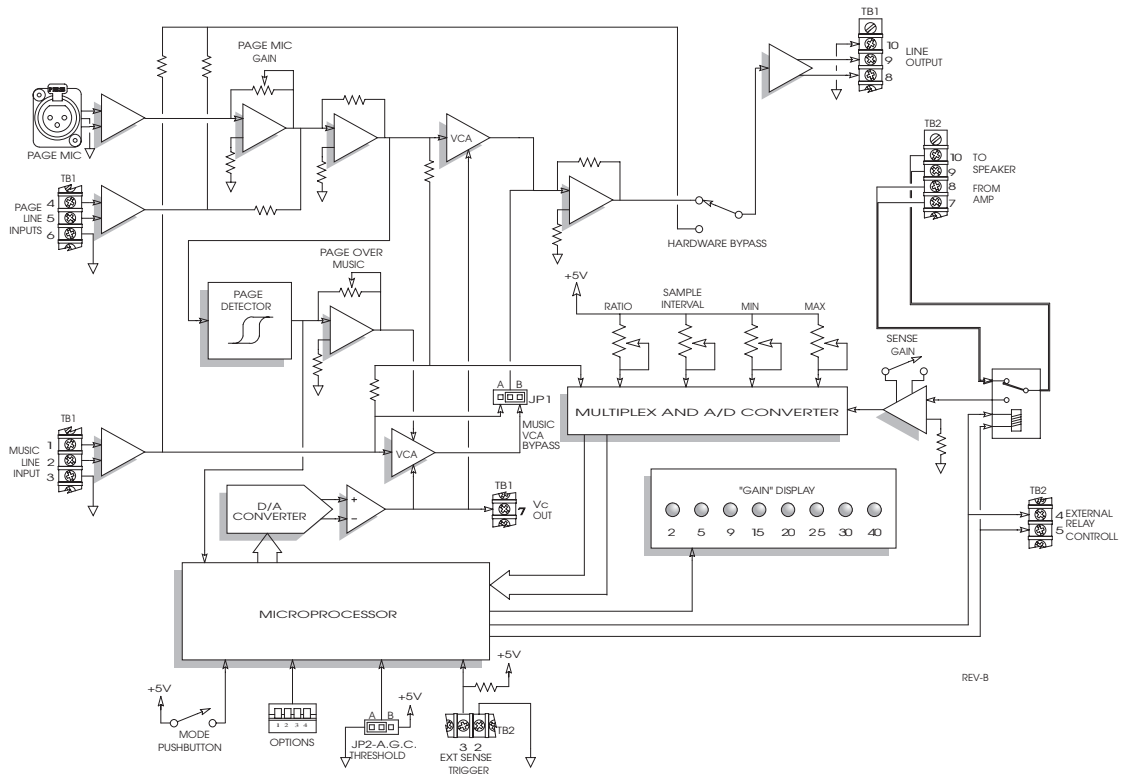

Figure 7-1. 572 Block Diagram.

## Operating Format

The 572 has three operating modes: **OPERATE**, **CALIBRATE**, and **BYPASS**. You access these modes by sequentially operating the **MODE** switch or by pressing the **BYPASS** switch. Each push of the mode switch toggles the operating mode between **CALIBRATE** and **OPERATE**.

## Bypass, Calibrate and Error Indicators

The front-panel LED bargraph also serves as a status indicator. Two of the LEDs serve as prompts during calibration, one other LED serves as an error indicator during calibration.

If the error indicator flashes during calibration, the calibration procedure automatically aborts and the 572 returns to operate mode using the calibration values previously stored in nonvolatile memory. The 572 cannot be recalibrated until the problem causing the error is corrected.

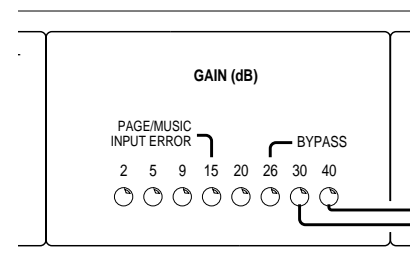

Figure 7-2 LED Bargraph

## Options, Options, Options

The 572 has many operational options, mostly controlled by a 4-wide DIP switch located on the front panel. The microprocessor scans the switches continuously; any changes in their settings are acted upon almost instantaneously.

The four option switches set the music silence threshold level, sense view (displays sense level on front panel bargraph), ambient sample averaging, and external sense control.

# 572

---

## Calibration

---

Calibration must be performed when the ambient noise in the loudspeaker coverage area is at its normal minimum level for the area. (NOT dead quiet, unless that is normal.)

1. Complete all input and output connections. There must be program audio present at a **LINE INPUT** connection before calibration can be completed. If the system is used for paging, activate the paging system by having an assistant count or recite the alphabet during the entire calibration procedure. The audio input level must be greater than -35 dBu or the 572 will not recognize the presence of audio and the **MUSIC/PAGE ERROR** light will flash.
2. Warn any people present that sound system may get momentarily loud.
3. Set the front panel controls as described in Calibration Settings Table (previous page).
4. Verify that program audio is audible in the system speakers.
5. Set the system power amplifier's volume control to a comfortably loud level. Do not readjust this control after calibration of the 572 or your calibration will be invalid.
6. Set the **BYPASS** switch to the OUT position.
7. Use a pencil to push the **CALIBRATE** button in and then release it.
8. The red MIN lamp lights. Adjust the **MIN CALIBRATE** knob to a comfortable listening level. The system audio level will stay at this level for 10 seconds. This level is the minimum level that the 572 allows in the space, regardless of how quiet the ambient noise level may be or get.
9. When the red MAX lamp lights adjust the **MAX CALIBRATE** knob to set the system level to as loud as you ever want the volume to go during noisy times. Check that the power amplifier(s) aren't clipping. The system audio level will return to normal in 10 seconds. It may be helpful to monitor the acoustical level in the space with a sound level meter.
10. Calibration is complete. The 572 will adjust the system level as the ambient noise in the area increases.

## Quick System Test

---

- While talking loudly or making noise near a system speaker turn the **SAMPLE INTERVAL** control to "1" and then quickly return it to "5". This forces the system to sense. The system level should increase in response to the increase in ambient noise.
- While remaining quiet, turn the **SAMPLE INTERVAL** control to "1" and then quickly return it to "5". This forces another sense. The system level should return to the minimum level.

## Options, Options and More Options

---

The option switches allow tailoring the 572 to different installation scenarios. There are four option switches.

**Option A** sets the music silence threshold. This threshold is the signal level at the **MUSIC LINE INPUT** that the 572 considers silent. Signals below this threshold are considered silent, and are fair game for sense intervals. In installations where the ambient noise level is fairly low, and where the background music has a great deal of dynamic range (like classical music from a CD player), you may need to keep the signal level through the 572 quite high, as well as using the lower silence threshold, and reducing the gain at the power amplifier input to put the music back to a comfortable level. This prevents the 572 from punching holes in the program material during quiet passages.

**Option B** forces the 572 to sense mode and displays the output of the sense preamplifier on the front-panel bargraph. Use option B to view the signal level returned from the loudspeakers in sense mode and to verify that the signal level falls within the 572's limits for proper operation. The ideal



indication should fall between the 5 dB and 26 dB LEDs on the calibration display. If necessary, use the **SENSE GAIN** switch on the front panel. Don't leave **SENSE VIEW** engaged as it prevents normal operation!

**Option C** enables sample averaging. If option switch C is down, the 572 computes the gain change solely on the basis of the current sample. If option switch C is up, the 572 computes the gain change based on the average of the current sample and the running average level (the 572 then squirrels away the new average for the next sample period).

**Option D** enables the **EXTERNAL SENSE** feature accessed from TB2-3 on the rear panel. Use this feature as described in Appendix B of the manual, or to force a sense period based on an external contact closure (sense triggering occurs when TB2-3 is connected to TB2-4/ground). The 572 remains in sense mode for the duration of the contact closure. This option also disables the **SAMPLE INTERVAL** timer and the 572 will only enter sense mode when TB2-3 is grounded.

|                               |                  |      |                 |
|-------------------------------|------------------|------|-----------------|
| <b><u>Option Switch A</u></b> | SILENCETHRESHOLD | UP   | -20 dBu         |
|                               |                  | DOWN | -35 dBu         |
| <b><u>Option Switch B</u></b> | SENSE VIEW       | UP   | Enabled         |
|                               |                  | DOWN | Disabled        |
| <b><u>Option Switch C</u></b> | SAMPLEAVERAGING  | UP   | Running Average |
|                               |                  | DOWN | No Average      |
| <b><u>Option Switch D</u></b> | EXTERNALSENSE    | UP   | Enabled         |
|                               |                  | DOWN | Disabled        |

## What Could Go Wrong?

Here are the two most common situations and some things to look for.

### The red MUSIC/PAGE lamp flashes during calibration:

1. There is no audio at the **LINE INPUT** from the program source. In a Paging Only system there must be a page in progress during the entire calibration procedure.
2. The audio input level to the 572 is too low. With the **OPTIONS** dip switch "A" in the up position the input level must be greater than -20 dBu. If the switch is in the down position the input level must be greater than -35 dB.
3. There are no speakers connected to terminals 9 and 10, **To SPEAKER**. The 572 uses the system speakers as microphones when sensing.

### The 572 does not accurately adjust the system level as ambient noise changes:

1. Repeat the calibration procedure. Calibration must be made during times of minimum background noise or the minimum system level will be inaccurate.
2. If the maximum level was set too high during calibration the system will get too loud as the background noise level increases.
3. If the maximum level was set too low the system will not be loud enough when the ambient noise level reaches its peak.
4. Ensure that all speakers are operating in-phase.

# 572

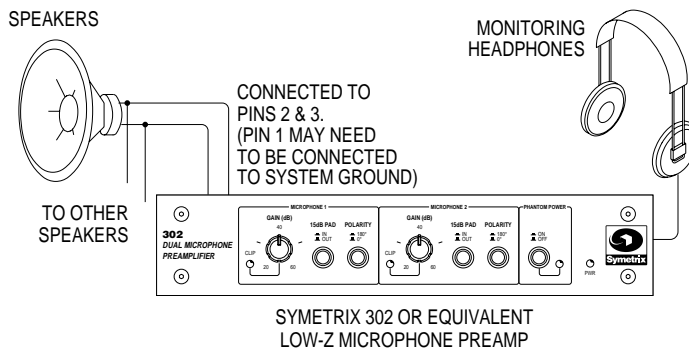

Figure 7-3 Using a microphone preamp to hear the sense speakers.

5. If hum is being induced in the speaker wiring the 572 will treat this noise as “sense” audio when sensing. Make sure that the speaker wiring is not routed next to AC wiring or unrelated 70V speaker wiring. Disconnect the speakers from the system and using a microphone preamplifier connected to the speaker(s), listen in headphones to what the 572 “hears” when it is sensing. Listen for any noises that could falsely trigger a gain change. Listen for any hum or buzz.
6. **The accuracy of the 572 is only as good as the sample audio that your speakers provide when the unit is sensing.** If any of the system speakers are located near noisy equipment such as vending machines, ice machines, air conditioning blowers, or separate paging speakers the level of the 572 system will increase disproportionately with the noise level of the noisy equipment. Disconnect the speakers from the system, connect them to the input of a balanced, low-impedance microphone preamp (like the Symetrix 302 shown in Figure 7-3) and listen in headphones to what the 572 “hears” when it is sampling!
7. Check Chapter 9 in this manual.

If all else fails, call Symetrix.

## Using the 572 in High-noise Environments

In noisy locations, it's important to locate the speakers where they do the most good, both for the listener as well as the 572. Remember that if the speaker is next to a noisy machine, the machine's noise output will probably cause the 572 to raise the level when the machine is operating. If this isn't desirable, then exclude that particular speaker from the speakers used for sensing by connect the offending speaker(s) directly to the amplifier output, bypassing the 572. In other cases, directional (horn) speakers may help by directing the sound to the listener. Horns are also more efficient, making your amplifier power go further. You can also put a sensing speaker somewhere where the noise level is more representative of the average noise level in the space even though there may not be anyone who can hear it. On the other hand, this may be a more appropriate application for the 571 (which uses a sensing microphone).

## Low Frequency Sensitivity

The sensing circuit of the 572 includes a 3-pole high pass filter. The 572 will not respond to background noise below 300 Hz. This design makes the system insensitive to building rumble and air handling noise. The sense circuit responds to signals between 500 Hz and 15 kHz.

## Using the 572 With Horn Speakers

Several users have had difficulty getting the 572 to calibrate and operate properly when connected to strings of high gain horn speakers in high noise environments. The horns returned too much signal to the 572 when it was sampling, which overloaded the A/D converter. In one case we were able to get the system to operate by increasing R13 and R14 to 91K0. If you set OPTION switch B

# 572

---

UP and the sense level indication exceeds the 26 dB LED in both positions of the **SENSE GAIN** switch, you need to increase R13 and R14.

In other cases using a single speaker as the sensing transducer was the only answer. In these cases the output of the power amplifier connects directly to the speaker string and the single sampling speaker is wired to TB2-9 and TB2-10 (**TO SPEAKER** terminals) of the 572. Terminals TB2-7 and 8 (**FROM POWER AMP**) are not connected. When the 572 samples it only looks at the single speaker for a reference level of ambient noise. In these cases the Symetrix 571 should have been specified for the job.

### Using the 572 With Planar or Low Output Speakers

---

Some speakers make lousy microphones. In a situation like this, we recommend using a separate speaker(s) for sensing. To do this, connect all of the speakers used to produce sound to the amplifier output. Connect all of the speakers used for sensing to the 572's **TO SPEAKER** terminals. If you wish these speakers to produce sound, then connect the 572's **FROM AMP** terminals to the amplifier output, otherwise leave the **FROM AMP** terminals unconnected. During sensing, the 572 sets the VCA to about 30 dB attenuation, so the speakers connected directly to the amplifier outputs are effectively silenced.

### 70V Systems

---

The 572 has been designed with both 70V (or other constant-voltage system) and speaker-impedance systems. Aside from the amount of current flowing through the 572's sense relay, the only other difference arises from the signal level returned by the speakers when the 572 switches to sense mode. In 70V systems, the signal level is higher, because of the step-up action of the line transformers. With highly-efficient speakers, this may present a problem because the sense input of the 572 may be overloaded. Use **OPTION** switch B to check the level coming back. Refer also to the discussion of option switches on pages 17 -18. The sense relay's 5A contact current limit forces a 300-watt wattage limit for 70V systems.

In 70V systems, it is common practice to provide autotransformers or L-pads after the line transformer to allow local volume control. NOT! Allowing any sort of level control after the 572 invalidates the settings made during calibration. If you must provide a local level control, then ensure that the controlled zone is a minor part of the entire system, that the users understand that the volume level of the system may not always be ideal, and (finally) that the locally controlled zone is not used for sensing.

Finally, it is imperative that every speaker and transformer in the system operates in-phase.

| <u>Impedance</u> | <u>Limit</u> |
|------------------|--------------|
| 16-ohms          | 400 watts    |
| 8-ohms           | 200 watts    |
| 4-ohms           | 100 watts    |

### 4, 8, and 16-ohm systems

---

In 4, 8, and 16-ohm systems (speaker-impedance systems), the levels returned to the 572 are low; you'll probably need to use the high-gain position of the **SENSE GAIN** switch. The 5A contact current limit forces the following limitations:

Refer also to the paragraph regarding zone volume controls in the preceding section.

### Using the External Relay Provisions

---

When controlling amplifiers larger than 200 watts (8-ohms) you really should be using the Symetrix 571. If you insist on using the 572, you **must use** an external DPDT relay. The 572's internal relay cannot handle more than 5-amps of load current. This corresponds to 300 watts at 70V, 200 watts at 8-ohms, and 100 watts at 4-ohms. The 24-volt version of the Potter & Brumfield PRD11DGO works well. Its DPDT contacts are rated at 30 amps. Figure 7-4 shows how to connect everything.

572

The 572 provides a contact closure through a transistor switch to operate the external relay. This closure can be found on the rear panel barrier strip TB2-5 which is labeled **EXT RELAY CNTRL**. Terminal TB2-6 is ground. Wire the negative output of your external power supply to TB2-6 (Ground). Connect the positive output of the power supply to one side of the external relay coil. Connect the other side of the relay coil to TB2-5. The user supplied power supply and external relay coil circuit is closed whenever the 572 goes into the SENSE mode. Be sure to put a back-biased diode (1N4002 or better) across the relay coil.

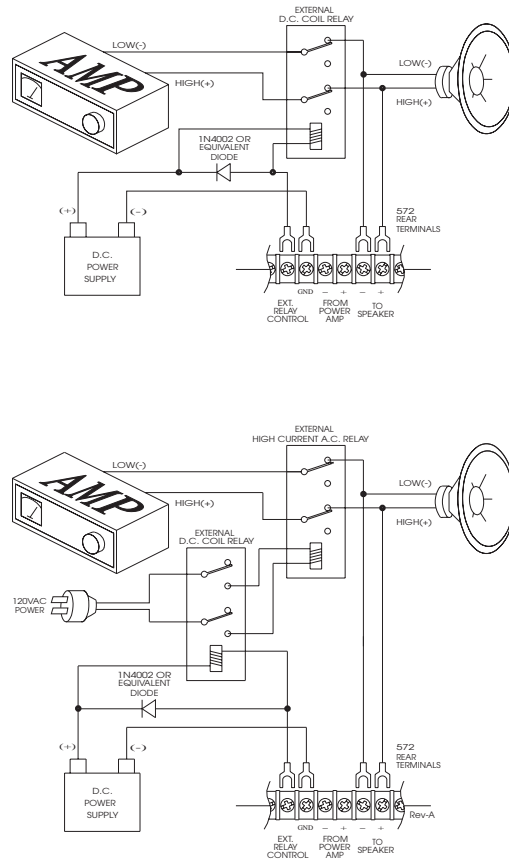

Figure 7-4 Using the External Relay connections.

## What does the Ratio Control Do?

The **RATIO** control acts much the same as the ratio control on a compressor or expander: it affects the amount of change at the output for a given change at the input. In the 572, the **RATIO** control determines how much the output changes for a given change at the sense input. In the 12:00 position, the ratio is 1:1; a 1 dB sense change results in a 1 dB output change. Turning the **RATIO** control clockwise results in expansion: in the 1:2 position (full CW), a 2 dB change at the sense input results in a 4 dB output change. Turning the **RATIO** control counterclockwise results in compression: in the 2:1 position, a 2 dB sense input change results in only a 1 dB output change.

Use the **RATIO** control when you either want the 572 to more than keep up with the crowd (expansion), or when you want it to lag behind when the crowd is loud (compression). Another reason to use “compression” might be when the available amplifier power is limited. Last, you must decide whether or not you want the sound system to be capable of “out-shouting” the crowd.

## Monitoring the VCA Gain Via the $V_c$ Terminal

You can monitor what the VCA is doing via the  $V_c$  terminal on TB1-7. The gain relationship is -159 mV/dB. Don't worry about what the actual value of the gain or loss (it's unity gain @ 0 V), it's the change in gain and the actual starting/stopping values that count. For instance, after calibration, the VCA control voltage is sitting at 1 volt (-6.289 dB loss through the VCA). After the first sense interval, the control voltage now sits at -1 volt (about 6.289 dB gain). The VCA gain has changed by 12.58 dB (overall gain increase). The front panel gain display will read 9.

# 572

---

## Calibration Issues

---

If you want the 572 to operate correctly then proper calibration is an absolute necessity. The calibration procedure establishes the high and low limits (level-wise) for the sound system. It also establishes the baseline noise level for the space. Therefore, it is imperative that the calibration be performed at a time when the space is at or near its nominal minimum and that you have the ability to operate the sound system at its maximum desired level for short periods of time.

It is not possible to calibrate the 572 properly at other than the lowest normal ambient for the space. Do not calibrate when the space is dead quiet, unless that is the lowest normal ambient level.

## Effects of Calibration Level on Performance

---

The calibration procedure sets two gain values (MINL and MAXL), and establishes a baseline SPL threshold level (BTL). The baseline SPL threshold is the lowest SPL that the 572 will respond to. Below the BTL, there will be no gain changes. Thus, the level set by the MIN pot during calibration becomes the minimum output level (MINL) of the 572. If the room ambient falls below the BTL, the output of the 572 remains at MINL.

The MAXL corresponds to the maximum output level of the 572, regardless of the setting of the RATIO control, or the ambient noise level. The rule here is the change in ambient level times the slope may not exceed MAXL. If the computed gain change passes the test, then that value drives the VCA, if not, then the change is limited to MAXL.

If the BTL level is too low, relative to the actual minimum ambient level (AMAL), then the 572 could run out of control range. This is what would occur if you tried to use silence to set the BTL. If the AMAL level is marginally too low, then simply ensure that there is a low enough MIN setting to allow the sound system to track this minimum level. On the other hand, you could establish a minimum level (to ensure that the sound system is always heard) by making this the difference between the BTL and MINL.

If the BTL level is higher than the AMAL, then the sound system is likely to be too loud when the space is at its quietest. Reducing the amplifier gain will work, but you must ensure that there is enough gain-change range (difference between MIN and MAX controls) to keep up with a noisy environment.

## Summary of Level Considerations

---

1. It is best to try to hit the Baseline SPL Threshold Level on the head, or certainly within 6 dB.
2. Be sure that you have more Maximum Level than you need, which will help compensate if the
3. Baseline SPL Threshold Level is higher than the Actual Minimum Ambient Level.

# 572



Here are a few applications that the 572 lends itself to. It's important in every one of these applications (actually, any 572 application) that the unit has been properly calibrated and that the program material has sufficient silence periods for ambient sensing.

### Factories

---

In this application, the 572 monitors the ambient noise level within a factory and adjusts the sound system's operating level to ensure that it is always audible. Ensure that all speakers that are used for sensing are installed so that they receive an average of the noise sources within the space to ensure that a loud, localized noise source does not dominate the control of the sound system. For speakers that are near a noise source, you may need to wire these speakers directly to the power amplifier, bypassing the 572. If the sound system needs to be heard consistently in spite of the localized noise source, you may need to create a controlled zone at the source by dedicating a 572, speaker(s) and an amplifier to that purpose.

Speakers serving "quiet zones," such as break rooms, offices, and rest rooms, should probably be on their own amplifier, fed from the input of the 572 (so that they are unaffected by the 572).

### Restaurants, Bars & Theme Stores

---

All of these establishments have one thing in common: they all use background or foreground music as an integral part of their ambiance. The volume level of the music is important; audible, but not too audible. How audible is not the judgement of the kid that works the counter. It's a management decision. The 572 helps guarantee the audibility of the music regardless of actual conditions during operation.

Again, picking the right speaker locations is the key. In a restaurant, avoid using speakers near the kitchen, entry areas, and espresso machines for sensing.

In bars and lounges, keep any speakers mounted near the blenders and dishwashers behind the bar out of the sensing circuit. Remember that any extraneous sound sources (like the TV in a sports bar) will be regarded as extra ambient noise by the 572 and the sound system level will increase as a result. You can try to avoid this by running the TV sound through the 572 so that the TV sound becomes part of the 572's throughput. The 572 will force a sample if it doesn't see silent periods that are long enough to use for sensing in the TV programming. This could be a problem during "Monday Night Football."

### Shopping Malls

---

In this application, the 572 ensures that announcements within the public spaces are always audible, but never too loud. In mall applications, it's a good idea to wire speakers mounted near localized noise sources (like the kiddie area) directly to the power amp so that they are not used for sensing. Like the factory application, you want the sense speakers to average out all of the various noise sources within the mall.

For high-noise areas, it's a good idea to create separate coverage zones each with their own 572.

### Auditoriums and Hotel Lobbies

---

Here the 572 keeps track of the ambient conditions in the outer areas such as the lobbies and foyers. If you have speakers in the rest rooms, these speakers should probably not be under the 572's control since these areas are generally more subdued than the outer areas and you wouldn't want flushing a toilet to raise the SPL in the lobby (or maybe you do...).

### Sports Facilities

---

Sports facilities, like auditoriums, can benefit from the 572. Again, the 572 tracks the ambient conditions on the concourses, other access areas, and the refreshment stands. Consider using multiple 572s to isolate specific noise sources and their environments from each other, such as the refreshment stands from the concourse environment. Since the 572 uses the existing speakers, this could be an aftermarket add-on.

A large, stylized, dark grey graphic of the number '572' is positioned vertically on the right side of the page. The digits are thick and blocky, with a slight shadow effect, giving it a three-dimensional appearance. The '5' is at the bottom, the '7' is in the middle, and the '2' is at the top.

---

## Off-Track Betting Parlors and Casinos

---

In these facilities, the crowd reaction is likely to be sudden and intense. If the program material doesn't have long enough silent spots for sensing, the 571 is a better idea since it works in real time.

In casinos, be sure to place the to average the crowd and the machines, especially the dollar machine with the 20-jillion dollar jackpot.

## Museums

---

Now why would you want to put a 572 into a museum? When the museum has an overall paging system. That when.

What about when the museum has automated exhibits? That's not when. Use a 571 instead because the 571 works in real time. The time delays between sensing periods and operating periods would most likely result in sound systems that are too loud for the current ambient condition.

## Airports, Train Stations, etc.

---

The 572 is ideally suited to managing the SPLs within airports and other transportation hubs. Within airports, use at least one 572 per paging zone.

In subway stations, pick a speaker location that favors the crowd but still 'hears' the trains. Doing so ensures that the level increases when a train is present.

Make sure that there are sufficient silent periods for sensing. You can use the mic-level page input for the local paging mic and the line-level paging input for facility-wide paging. Use the music input for background music, if any.

## Race Tracks

---

Different race tracks have different noise sources. In auto racing, the cars usually make more noise than the spectators. If you're going to apply a 572 to a speedway, position the speakers so they are in a good spot to pick up the cars as well as the crowd.

If this isn't practical, consider using a small paging speaker(s), with a 70V transformer<sup>1</sup> that is only used as a microphone. Use a moderate transformer tap, like 10 watts. You may even be able to do away with the transformer. Use shielded twisted-pair cable and don't forget to tie the shield to the case of the speaker (or float it if it's plastic or to avoid a ground loop.). Position the speaker so it has a nearby view of the stands and connect it to the 572's TO SPEAKER terminals. Do not connect the amplifier to the FROM AMP terminals. Instead, connect the amplifier directly to the other loud-speakers.

In horse (and dog) racing, the spectators make more noise than the animals. In this case, the spectator area speakers serve as expected, both for paging as well as for sensing.

Use a short AVERAGING TIME. Ensure that the program material has enough dead spots to ensure frequent sensing. Definitely use a live mic when calibrating. Beware of acoustic feedback, especially when calibrating the MAX level.

<sup>1</sup> The ElectroVoice PA15BT-7 or PA30-AT are both suitable units.

572

**Symptom:**            Probable cause

**There is no output signal:**

- Check cables and connections. Are inputs driven by outputs, and outputs driving inputs?
- Determine that there really is a signal coming from the source and that it is getting to the 572.
- Is the signal chain after the 572 functioning?
- Check for AC power presence. Power LED on?
- Is the fuse OK?

**Unit will not calibrate:**

- Are input levels normal?
- Use Option Switch B to check sense gain. Change setting of SENSE GAIN switch.

**Music/Page LED flashes during calibration:**

- No audio at either line input or the page mic input.
- Input signal level too low. Change Option Switch A to the UP position.
- Speakers not connected at TO SPEAKERS terminals.

**Music always plays too loud:**

- MIN and/or MAX levels set incorrectly during calibration.

**Unit seems to have no effect:**

- Check the RATIO control. At 2:1, the gain changes are *very* subtle. Turn the RATIO control clockwise for more change.
- Bad calibration. Repeat calibration procedure during quiet time.
- MAX level set too low.

**Unit never senses, even during silence:**

- Option Switch D up. Change switch setting.

**Unit loses the beginnings of paging messages:**

- Paging signals should always drive the PAGE LINE INPUT or the PAGE MIC INPUT.

**Unit does not accurately adjust system as ambient noise changes:**

- Bad calibration. Repeat procedure during quiet time.
- Hum induced in speaker wiring. Ensure that speaker wiring is not routed adjacent to AC wiring.
- Disconnect speakers from 572 and connect to low-Z balanced mic preamp and listen on headphones.
- Speaker mounted near continuous noise source. Take the speaker out of the sensing system by connecting it directly to the amplifier output.

**Note**    The accuracy of the 572 is only as good as the sample audio that the speakers provide during sensing.

**Unit interrupts paging:**

- Use either of the PAGE inputs. They have a higher priority than the music input.

**Unit senses during paging:**

- Caused by long silent pauses during paging.

**Hum or buzz in output:**

- Check input connector wiring (refer to Appendix B).
- Ground loop. Check related system equipment grounding. Are all system components on the same AC ground?

**Distortion:**

- Check input signal. Is it already distorted?
- Line input signal may be too hot. Page mic signal may be too hot.
- Does the sound system have sufficient power for the SPL that you are trying to attain?
- If you are using a high Max setting, you may be overloading the input to your amplifier.
- Reduce MAX setting. Is something else clipping?

**Noise (hiss) :**

- Check input signal levels, and level control settings. Check gain settings on downstream equipment. Is the input signal already noisy?

**No audio:**

572 Specifications

|  |   |                         |   |
|--|---|-------------------------|---|
| <b>Input/Output</b>                                    |   | <b>Performance Data</b> |   |
| Inputs   | All Balanced, Transformerless   | Control Range           | Variable, up to 40 dB (-20 dB to +20 dB)  |
| Paging Mic<br>(For microphone level<br>paging signals) | Impedance >1800 Ohms<br>Nominal Level -80 dBu to -40 dBu<br>Maximum Level -30 dBu<br>CMRR >60 dB  | Noise to Gain Ratio     | Variable, 2:1 to 1:2  |
| Paging<br>(For line level paging signals)              | Impedance >40 kilohms<br>Nominal Level 0 dBu,<br>Maximum Level +18 dBu<br>CMRR >40 dB   | Sample Interval         | Forced: Variable, 1 min. to 26 min<br>Auto: Silence periods (< -30 dBm) > 800 ms<br>Page-Over Music: Variable, 0 to 15 dB |
| Music<br>(For line level music signals)                | Impedance >40 kilohms<br>Nominal Level -10 dBu,<br>Maximum Level +18 dBu<br>CMRR >40 dB<br>+21.5 dBu                                      | Frequency Response      | 20 Hz to 20 kHz + 1 dB, -0 dB   |
| Output   | Balanced, Transformerless   | THD+Noise               | <0.05% THD, unity gain, 1 kHz<br>music into balanced output   |
| Impedance  | 200 Ohms Balanced, 100 Ohms Unbalanced<br>Minimum load: 600 Ohms Balanced<br>Nominal Level 0 dBm<br>Maximum level +24 dBm (into 600 Ohms) | Signal to Noise Ratio   | >70 dB, ref: 0 dBu, unity gain<br>(30 kHz noise bandwidth)  |
|  |   | Gain (VCA at unity)     | Balanced Input to Unbalanced Output = 0 dB<br>Unbalanced Input to Balanced Output = 6 dB                                  |
|  |   | Voltage Control Scale   | 156 mV/ dB  |
|  |   | Software                | Copyright Symetrix, Inc. 1989   |
|  |   | <b>Physical</b>         |   |
|  |   | Size                    | 1.74 x 19 x 6.25 inches, 4.42 x 48.3 x 15.875 centimeters   |
|  |   | Weight                  | 8lbs (3.6 kgs)  |
|  |   | <b>Electrical</b>       |   |
|  |   | Power Requirements      | 117 V AC, 60 Hz, 0.1amp (approx. 12 watts)  |

Note: The maximum operating ambient temperature is 25 degrees C.

In the interest of continuous product improvement, Symetrix Inc. reserves the right to alter, change, or modify these specifications without prior notice.

572 Architects and Engineers Specifications

The ambient sensing automatic level controlling device shall regulate the operating level of a sound system in proportion to changing noise levels in the sound system’s operating area. The device shall be capable of adjusting gain control over 40 dB overall (max) range, and shall be governed by a microprocessor which shall be controlled by embedded software. The device shall vary its gain based upon measurements of the sound pressure level of ambient noise in the environment. These sound level measurements shall be made by the level controlling device through the loudspeakers otherwise used for the system’s output. To facilitate the use of the system’s loudspeakers as noise measuring “microphones” the device shall provide relay switching of the speaker line circuit so as to disconnect the speakers from the amplifier output and connect the speakers to its own sensing input. The device shall provide inputs for paging signals at microphone level (nominal -40 dBv) or line level (nominal 0 dBv), and for music signals at line level (nominal 0 dBv). The device shall have a Ratio control to vary the ambient noise-to-gain ratio continuously from 2:1 to 1:2, and a front panel switchable hard-wired bypass. Calibration of the automatic level controlling device shall be semiautomatic, and shall require switching the device to CAL Mode, and adjusting the minimum desired operating level and the maximum desired operating level. Calibration settings shall be continuously maintained in nonvolatile memory without the need for battery pack up power.

In addition to the various functions and general specifications mentioned above, the ambient sensing automatic level controlling device shall meet or exceed the following overall performance criteria: frequency response ±1 dB 20 Hz to 20 kHz, total harmonic distortion less than .05% at any attenuation from -40 dB to 0 dB (2 kHz), maximum paging microphone input level -30 dBv, maximum line input level +18 dBu, maximum output level +24 dBm into 600-Ohms (balanced). Minimum impedance at the microphone inputs shall be 1800 Ohms, minimum impedance at the line inputs shall be 10 kilohms. The device shall be housed in an all steel chassis designed to be mounted in a 1U (1.74”) space in a standard 19” rack.

The ambient sensing automatic level controlling device shall be the Symetrix model 572 SPL Computer.



## 572 Limited Warranty

---

Symetrix, Inc. expressly warrants that the product will be free from defects in material and workmanship for one (1) year. Symetrix's obligations under this warranty will be limited to repairing or replacing, at Symetrix's option, the part or parts of the product which prove defective in material or workmanship within one (1) year from date of purchase, provided that the Buyer gives Symetrix prompt notice of any defect or failure and satisfactory proof thereof. Products may be returned by Buyer only after a Return Authorization number (RA) has been obtained from Symetrix. Buyer will prepay all freight charges to return the product to the Symetrix factory. Symetrix reserves the right to inspect any products which may be the subject of any warranty claim before repair or replacement is carried out. Symetrix may, at its option, require proof of the original date of purchase (dated copy of original retail dealer's invoice). Final determination of warranty coverage lies solely with Symetrix. Products repaired under warranty will be returned freight prepaid by Symetrix via United Parcel Service (surface), to any location within the Continental United States. At Buyer's request the shipment may be returned via airfreight at Buyer's expense. Outside the Continental United States, products will be returned freight collect.

**The foregoing warranties are in lieu of all other warranties, whether oral, written, express, implied or statutory. Symetrix, Inc. expressly disclaims any IMPLIED warranties, including fitness for a particular purpose or merchantability. Symetrix's warranty obligation and buyer's remedies hereunder are SOLELY and exclusively as stated herein.**

This Symetrix product is designed and manufactured for use in professional and studio audio systems and is not intended for other usage. With respect to products purchased by consumers for personal, family, or household use, Symetrix **expressly disclaims all implied warranties, including but not limited to warranties of merchantability and fitness for a particular purpose.**

This limited warranty, with all terms, conditions and disclaimers set forth herein, shall extend to the original purchaser and anyone who purchases the product within the specified warranty period.

Warranty Registration must be completed and mailed to Symetrix within thirty (30) days of the date of purchase.

Symetrix does not authorize any third party, including any dealer or sales representative, to assume any liability or make any additional warranties or representation regarding this product information on behalf of Symetrix.

This limited warranty gives the buyer certain rights. You may have additional rights provided by applicable law.

## Limitation of Liability

---

The total liability of Symetrix on any claim, whether in contract, tort (including negligence) or otherwise arising out of, connected with, or resulting from the manufacture, sale, delivery, resale, repair, replacement or use of any product will not exceed the price allocable to the product or any part thereof which gives rise to the claim. In no event will Symetrix be liable for any incidental or consequential damages including but not limited to damage for loss of revenue, cost of capital, claims of customers for service interruptions or failure to supply, and costs and expenses incurred in connection with labor, overhead, transportation, installation or removal of products or substitute facilities or supply houses.

---

## Servicing the 572

---

If you have determined that your 572 requires repair services and you live *outside* of the United States please contact your local Symetrix dealer or distributor for instructions on how to obtain service. If you reside in the U.S. then proceed as follows:

At the Symetrix factory, Symetrix will perform in-warranty or out-of-warranty service on any product it has manufactured for a period of five years from date of manufacture.

**Before sending anything to Symetrix**, contact our Customer Service Department for a return authorization (RA) number. The telephone number is (425) 787-3222, Monday through Friday, 8AM (800 hours) though 4:30 PM (1630 hours), Pacific Time.

### In-warranty Repairs

---

To get your 572 repaired under the terms of the warranty:

1. Call us for an RA number.
2. Pack the unit in its original packaging materials.
3. Include your name, address, daytime telephone number, and a brief statement of the problem.
4. Write the RA number on the outside of the box.
5. Ship the unit to Symetrix, freight prepaid.

**We do *not* accept freight collect shipments.**

Just do these five things, and repairs made in-warranty will cost you only one-way freight charges. We'll prepay the return (surface) freight.

If you choose to send us your product in some sort of flimsy packaging, we'll have to charge you for proper shipping materials. If you don't have the factory packaging materials, then do yourself a favor by using an oversize carton, wrap the unit in a plastic bag, and surround it with bubble-wrap. Pack the box full of Styrofoam peanuts. Be sure there is enough clearance in the carton to protect the rack ears (you wouldn't believe how many units are returned with bent ears). We won't return the unit in anything but Symetrix packaging for which we will have to charge you. Of course, if the problem turns out to be operator inflicted, you'll have to pay for both parts and labor. In any event, if there are charges for the repair costs, you will pay for the return freight. All charges will be COD unless you have made other arrangements (prepaid, Visa or Mastercard).

### Out-of-warranty Repairs

---

If the warranty period has passed, you'll be billed for all necessary parts, labor, packaging materials, and freight charges. Please remember, you must call for an RA number before sending the unit to Symetrix.

# 572

## Appendix A External Sensing & Multi-Unit Installations

**OPTION** switch D enables the external sense input and prevents both periodic sensing and silence-based sensing. When **OPTION** switch D is UP, sensing only occurs when TB2-3 is held low (grounded). The unit remains in sense mode for as long as TB2-3 is grounded and you must ground the external sense line for a minimum of one second.

You use this feature when it is inappropriate to interrupt the program material based on either time or silence. Of course, you must have some other means of telling the 572 when to sense (electronic wizardry, slave labor, etc.).

**OPTION** switch D has one additional use: forcing multiple 572s to sample simultaneously. There are two reasons for doing this:

1. Adjacent sound systems to the controlled area are noise sources as far as the 572 is concerned. Their acoustical output influences the ambient sampling of other units. Simultaneous sampling removes adjacent systems from consideration as noise sources.
2. During sampling, the sampling speakers are connected to an extremely high-gain amplifier. Adjacent speaker wiring, in the same conduit or raceway, may cause crosstalk into the speaker wiring connected to the sampling speakers, which will cause erroneous results in the controlled zone.

Figure Appendix A-1 shows what is necessary for externally controlled sampling. Figure Appendix A-2 shows how to interconnect multiple 572s for simultaneous sampling.

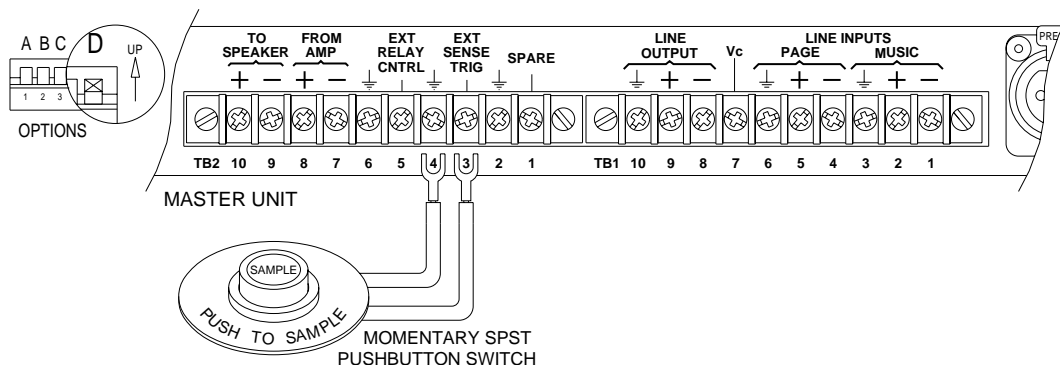

Figure Appendix A-1. Using option switch D and a remote momentary pushbutton for externally controlled sampling.

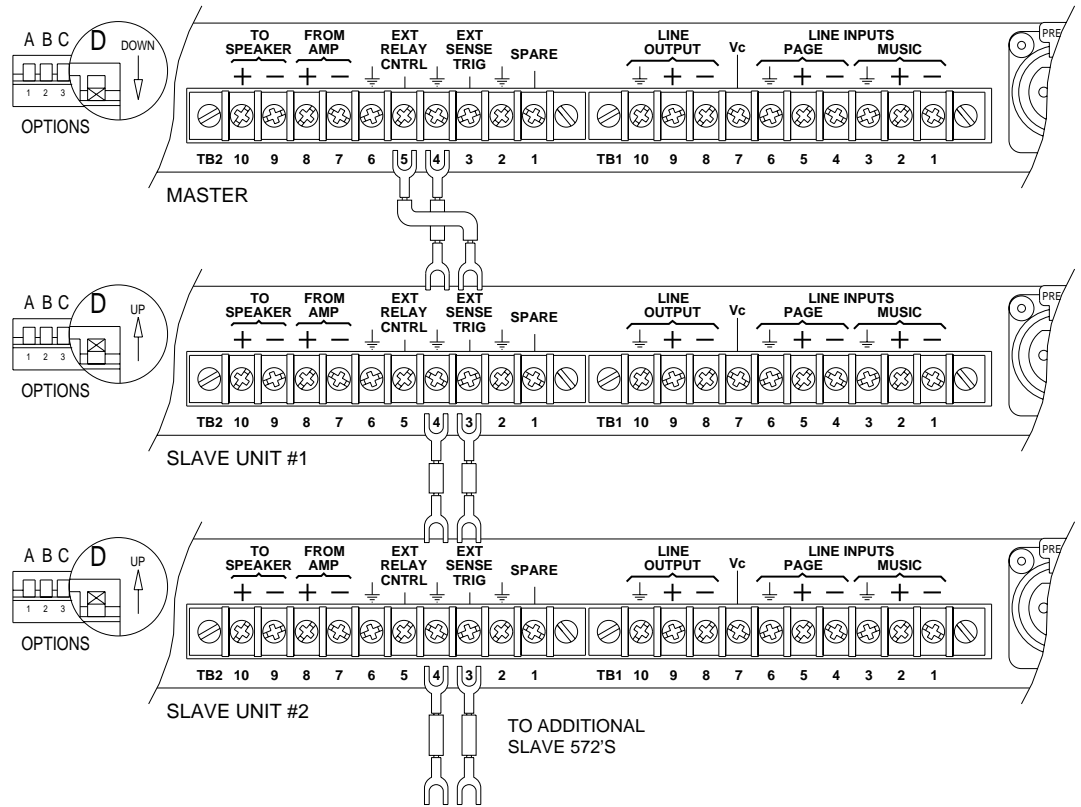
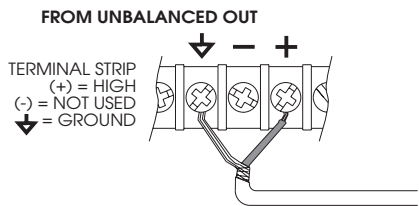
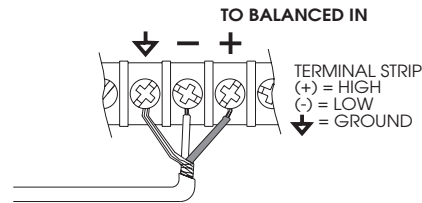
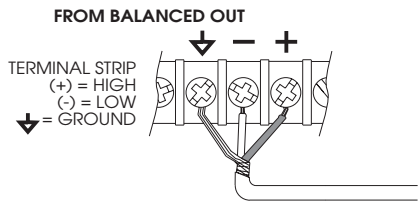
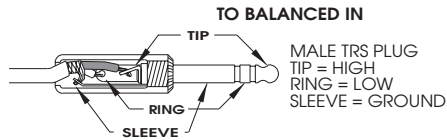
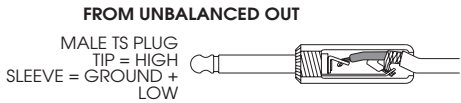
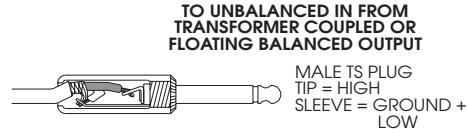
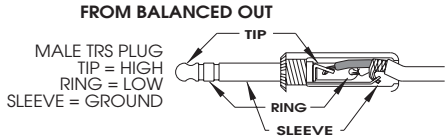
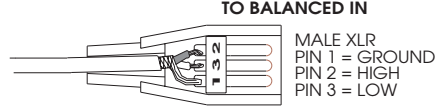
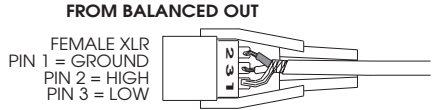

Figure Appendix A-2. Multiple 572 master-slave connections for simultaneous sampling.

# 572



Input and output connector wiring. These diagrams represent the majority of connectors used in modern audio equipment. Locate the source connector in the left column and match it up with the destination connector in the right column. Wire your cable according to the diagrams.



**FROM NON-TRANSFORMER (ELECTRONIC) BALANCED OUTPUT (TYPICAL OF SYMETRIX PRODUCTS)**

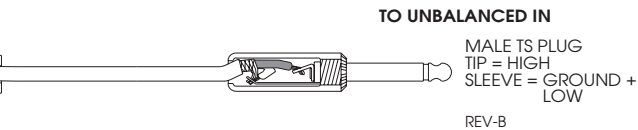

# 572

# 572

 **Symetrix**



**Symetrix, Inc.**

14926 35th Ave. West  
Lynnwood, WA, 98037-2303  
USA

Tel: (425) 787-3222

Fax: (425) 787-3211

Website: <http://www.symetrixaudio.com>

Email: [symetrix@symetrixaudio.com](mailto:symetrix@symetrixaudio.com)